

BLIZZARD[®] **SNOWPLOWS**



Models 760LT, 760HD, 800HD & 860HD **Installation Instructions & Owner's Manual**

⚠ CAUTION

Read this manual before operating or servicing snowplow.

This document supersedes all editions with an earlier date.

PREFACE

Congratulations on purchasing the finest straight blade snowplow available! BLIZZARD® straight blades are clearing new trails for innovative design, rugged durability, quality craftsmanship and superior performance. Our exclusive products are

manufactured and tested in Michigan's Upper Peninsula, the snow capital of the Midwest. With an annual snowfall averaging over 250" we couldn't imagine building snow removal products anywhere else!

TABLE OF CONTENTS

Preface	2	Testing Your Snowplow	30
Safety Information	4	Headlight Aiming	32
Operation	7	Maintenance	33
Unpacking & Inspection	8	Technical Specifications	34
Torque Specifications	9	Troubleshooting	35
Moldboard & A-Frame Assembly	11	Notes	37
Electrical & Hydraulic Systems	16	Parts Lists	38
General System Schematics	16	Moldboard & Wing Parts – All Models	38
Hydraulic Guide	17	A-Frame & Pivot Beam Parts – All Models	40
Electrical Installation – Snowplow Side	18	Power Unit Parts – All Models	42
Electrical Schematics – Snowplow Side	19	Lights, Draw Latch & Control Parts – All Models	44
Electrical Installation – Vehicle Side	22	Harnesses, Accessories & Kits – All Models	46
Electrical Schematics – Vehicle Side	25	Notes	51
POWER HITCH™ System Instructions	29		

SAFETY

SAFETY DEFINITIONS

WARNING

Indicates a potentially hazardous situation, that if not avoided, could result in death or serious personal injury.

CAUTION

Indicates a potentially hazardous situation that, if not avoided, may result in minor or moderate injury. It may also be used to alert against unsafe practices.

NOTE: Indicates a situation or action that can lead to damage to your snowplow and vehicle or other property. Other useful information can also be described.

WARNING/CAUTION & INSTRUCTION LABELS

Become familiar with and inform users about the warning and instruction labels on the back of the blade.

NOTE: If labels are missing or cannot be read, see your sales outlet.

MOUNT INSTRUCTIONS		DISMOUNT INSTRUCTIONS
<p>STEP #1</p> <p>CONNECT/DISCONNECT Power Hitch Switch</p> <p>Push Beam Receiver Mount Points</p> <p>Adjustable Kickstand</p> <p>A-Frame Mount Bracket</p> <p>Undercarriage Push Beams</p> <p>Power Hitch</p> <p>Slowly Move Vehicle Forward</p> <p>CAUTION: KEEP FINGERS AWAY! POWER HITCH RAISES BEHIND UNDERCARriage PUSH BEAM.</p> <ul style="list-style-type: none"> Kickstand should be in the lowered position. Slowly drive vehicle forward until the push beam receiver mount points contact the A-frame mount brackets. Turn POWER HITCH OPERATION switch (on plow control) to the "ON" position. Connect plow and vehicle electrical harnesses. 		<p>STEP #1</p> <p>CONNECT/DISCONNECT Power Hitch Switch</p> <p>Adjustable Kickstand</p> <p>Power Hitch</p> <p>Slowly Back Vehicle Away</p> <p>CAUTION: KEEP FINGERS AWAY! POWER HITCH LOWERS FROM UNDERCARriage PUSH BEAM.</p> <ul style="list-style-type: none"> With the plow fully raised, lower the kickstand. Lower plow on a flat, level surface. Turn vehicle ignition off. Remove hitch pins from the A-frame and undercarriage. Turn vehicle ignition on. Verify POWER HITCH OPERATION switch (on plow control) is in the "ON" position.
<p>STEP #2</p> <p>POWER HITCH OPERATION</p> <p>A-Frame Latch Lock Pin</p> <p>A-Frame Latch</p> <p>A-Frame Latch Retains Kickstand And Hooks Onto Draw Pin</p> <p>Draw Pin</p> <p>Connect electrical harness plugs to mount plow and disconnect plugs prior to dismounting plow.</p> <p>CAUTION: KEEP FINGERS AWAY FROM PLOW & TRUCK MOUNTING POINTS!</p> <ul style="list-style-type: none"> Push and hold the CONNECT/DISCONNECT switch upward. The Power Hitch will disengage from behind the undercarriage push beam and lower. Disconnect plow and vehicle electrical harnesses. Install weather caps. Turn SYSTEM POWER (on plow control) to the "OFF" position. Slowly back vehicle away from plow. <p>BL 1077</p>		<p>STEP #2</p> <p>CONNECT/DISCONNECT Power Hitch Switch</p> <p>Adjustable Kickstand</p> <p>Power Hitch</p> <p>Slowly Back Vehicle Away</p> <p>CAUTION: KEEP FINGERS AWAY FROM PLOW & TRUCK MOUNTING POINTS!</p> <ul style="list-style-type: none"> Push and hold the CONNECT/DISCONNECT switch downward. The Power Hitch will disengage from behind the undercarriage push beam and lower. Disconnect plow and vehicle electrical harnesses. Install weather caps. Turn SYSTEM POWER (on plow control) to the "OFF" position. Slowly back vehicle away from plow.

WARNING

LOWER BLADE WHEN VEHICLE IS PARKED.

REMOVE BLADE ASSEMBLY BEFORE PLACING VEHICLE ON HOIST.

DO NOT EXCEED GVWR OR GAWR INCLUDING BLADE AND BALLAST.

CAUTION

READ OWNER'S MANUAL BEFORE OPERATING OR SERVICING SNOWPLOW.

TRANSPORT SPEED SHOULD NOT EXCEED 45 MPH. REDUCE SPEED UNDER ADVERSE TRAVEL CONDITIONS.

PLOWING SPEED SHOULD NOT EXCEED 10 MPH.

SEE YOUR SALES OUTLET FOR APPLICATION RECOMMENDATIONS.

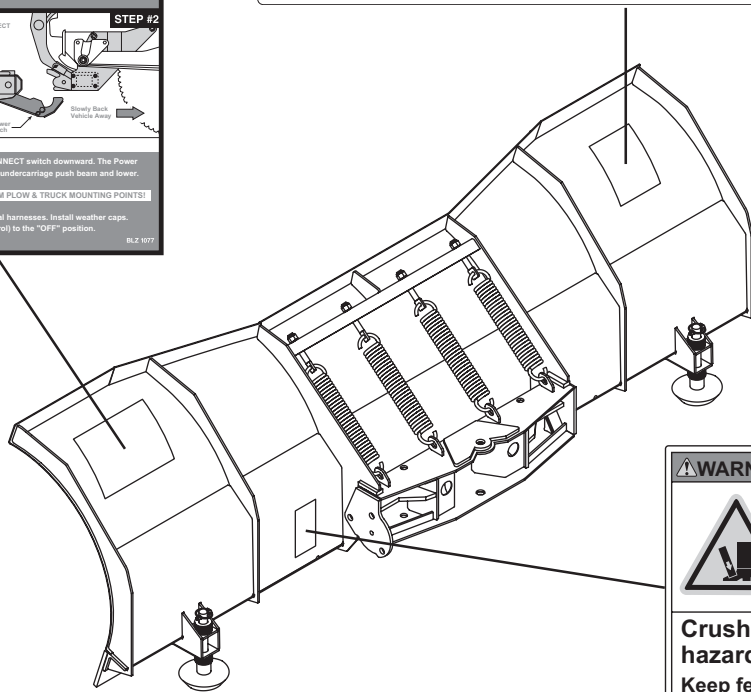

WARNING



Crush hazard. Keep feet clear.

SAFETY

SAFETY PRECAUTIONS

Improper installation and operation could cause personal injury, and/or equipment and property damage. Read and understand labels and the *Owner's Manual* before installing, operating or making adjustments.

⚠ WARNING

Lower blade when vehicle is parked. Temperature changes could change hydraulic pressure, causing the blade to drop unexpectedly or damaging hydraulic components. Failure to do this could result in serious personal injury.

⚠ WARNING

You can die or be seriously injured. Keep hands and feet away from hitch mechanism and snowplow blade when operating the POWER HITCH™ arm. The action of the arm moves the snowplow toward the vehicle and into position for proper attachment.

⚠ WARNING

The driver shall keep bystanders clear of the blade when it is being raised, lowered or angled. Do not stand between the vehicle and the blade or within 8 feet of a moving blade. A moving or falling blade could cause personal injury.

⚠ WARNING

Do not exceed GVWR or GAWR including the blade and ballast. The rating label is found on the driver-side vehicle door cornerpost.

⚠ WARNING

Remove blade assembly before placing vehicle on hoist.

⚠ CAUTION

Read Owner's Manual before operating or servicing snowplow.

⚠ CAUTION

Transport speed should not exceed 45 mph. Reduce speed under adverse travel conditions.

⚠ CAUTION

Plowing speed should not exceed 10 mph.

⚠ CAUTION

See your BLIZZARD® outlet for application recommendations.

⚠ CAUTION

To prevent accidental movement of the blade, always turn the ON/OFF switch to OFF whenever the snowplow is not in use. The control indicator light (touchpad only) will turn off.

HYDRAULIC SAFETY

⚠ WARNING

Hydraulic fluid under pressure can cause skin injection injury. If you are injured by hydraulic fluid, get medical attention immediately.

- Always inspect hydraulic components and hoses before using. Replace any damaged or worn parts immediately.
- If you suspect a hose leak, DO NOT use your hand to locate it. Use a piece of cardboard or wood.

FUSES

The electrical and hydraulic systems contain several automotive blade-style fuses. If a problem should occur and fuse replacement is necessary, the replacement fuse must be of the same type and amperage rating as the original. Installing a fuse with a higher rating can damage the system and could start a fire.

SAFETY

PERSONAL SAFETY

- Remove ignition key and put the vehicle in park or in gear to prevent others from starting the vehicle during installation or service.
- Wear only snug-fitting clothing while working on your vehicle or snowplow.
- Do not wear jewelry or a necktie, and secure long hair.
- Wear safety goggles to protect your eyes from battery acid, gasoline, dirt and dust.
- Avoid touching hot surfaces such as the engine, radiator, hoses and exhaust pipes.
- Always have a fire extinguisher rated BC handy, for flammable liquids and electrical fires.

FIRE AND EXPLOSION

⚠ WARNING

Gasoline is highly flammable and gasoline vapor is explosive. Never smoke while working on vehicle. Keep all open flames away from gasoline tank and lines. Wipe up any spilled gasoline immediately.

Be careful when using gasoline. Do not use gasoline to clean parts. Store only in approved containers away from sources of heat or flame.

VENTILATION

⚠ WARNING

Vehicle exhaust contains lethal fumes. Breathing these fumes, even in low concentrations, can cause death. Never operate a vehicle in an enclosed area without venting exhaust to the outside.

BATTERY SAFETY

⚠ CAUTION

Batteries normally produce explosive gases which can cause personal injury. Therefore, do not allow flames, sparks or lit tobacco to come near the battery. When charging or working near a battery, always cover your face and protect your eyes, and also provide ventilation.

Batteries contain sulfuric acid which burns skin, eyes and clothing.

Disconnect the battery before removing or replacing any electrical components.

NOISE

Airborne noise emission during use is below 70 dB(A) for the snowplow operator.

OPERATION

Your snowplow is the most advanced and versatile straight blade on the market. The easy-to-use controls allow you to automatically adjust the plow blade into an infinite number of plowing positions. Review the illustrations below for instruction on maneuvering your snowplow.

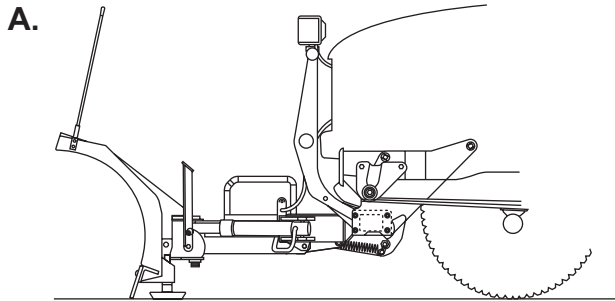

A. Lowered or Float Position

Pushing the joystick forward, toward the "Lower/Float" designation on the label, or pushing the "D" button on the touchpad will lower your straight blade to the ground. Pushing and momentarily holding the control in this position will allow the snowplow to "float", or follow the contour of the ground when moving forward or backward.

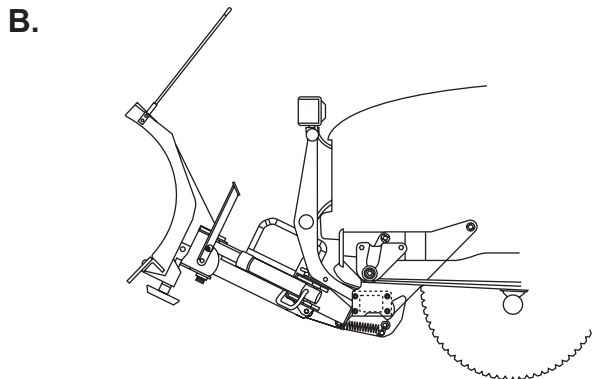

B. Raised Position

Pulling the joystick back, toward the "Raise" designation on the label, or pushing the "U" button on the touchpad will lift your straight blade off of the ground. To stop raising the plow, simply return the joystick to its "neutral", or center, position or release the touchpad button. The snowplow has reached its maximum raised position when the blade stops lifting.

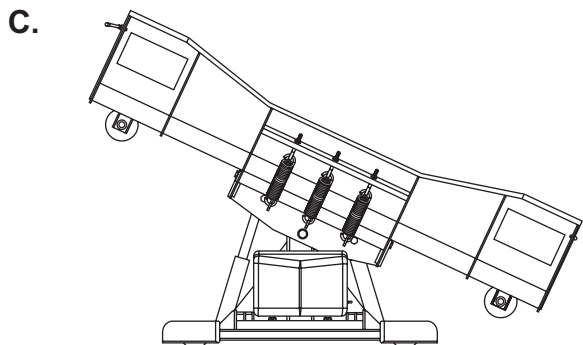

C. Angled Right Position

To angle your straight blade to the right, position the joystick toward the "R" on the label or push the "R" button on the touchpad. To stop angling the plow, return the joystick to its "neutral" or center position or release the touchpad button. The snowplow has reached its maximum angled position when the blade stops moving to the right side.

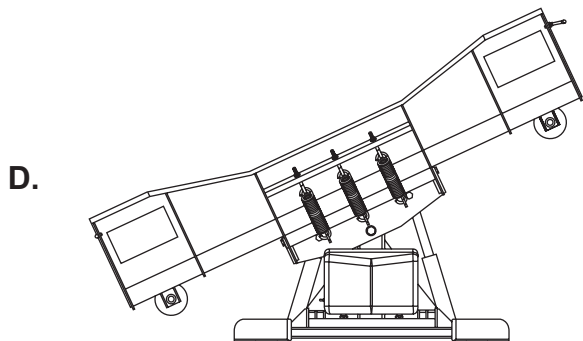

D. Angled Left Position

To angle your straight blade to the left, position the joystick toward the "L" on the label or push the "L" button on the touchpad. To stop angling the plow, return the joystick to its "neutral" or center position or release the touchpad button. The snowplow has reached its maximum angled position when the blade stops moving to the left side.

NOTE: To prevent premature failure of the power contactor (solenoid), return the joystick to its neutral (center) position or release the touchpad button immediately after the blade reaches the limit of any position. Continuing to hold the control after the blade has reached the limit of movement in any position will reduce the life of the solenoid.

UNPACKING & INSPECTION

Your BLIZZARD® straight blade has been packaged to withstand transit and weather related damage. Fully inspect all components upon receipt of your plow. In the event of shipping damage or missing parts, immediately contact our Customer Service Department at 1-888-680-8600.

Begin unpacking and inspection in the following order:

1. Remove the shipping document from the end panel of the pallet wrap. Retain all documentation for your records.
2. All wood framing and polyethylene material should be removed from the pallet for easy access to the snowplow.
3. Due to the odd shaped components and size of several assembly parts, various cable ties and corrugated material are used for scratch resistance and package orientation. Please remove these items prior to assembly.
4. Place the main blade assembly on a flat, level surface.

Once you have inspected all parts and removed all packaging materials, your snowplow is ready to be fully assembled.

Retain this information for your records.

Date of Purchase: _____

Dealer/Distributor: _____

Dealer Phone Number: _____

Snowplow Serial Number: _____

Hydraulic Pump Serial Number: _____

Serial Number Labels

The serial number label on the back of the blade (driver side) contains important information about the snowplow. The serial number is displayed directly above the bar code, and the model information is above the serial number. The first six digits in the serial number represent the manufacture date of the snowplow. This date is formatted "yymmdd", in the example below, the manufacture date would be February 16, 2006. A similar label can also be found on the hydraulic unit. The manufacture date is, again, the first six digits of the serial number. Be sure to note both serial numbers in the area at the bottom of the preceding column.



TORQUE SPECIFICATIONS

TORQUE CHART

⚠ CAUTION

Read instructions before assembling. Fasteners should be finger tight until instructed to tighten according to the torque chart. Use standard methods and practices when attaching snowplow including proper personal protective safety equipment.



Grade Identification for J429–Grade 5 Bolt



Grade Identification for J429–Grade 8 Bolt

SAE J429 Grade 5 Torque Values				SAE J429 Grade 8 Torque Values			
Nominal Thread Size	Clamp Loads (lbs)	Tightening Torque		Nominal Thread Size	Clamp Loads (lbs)	Tightening Torque	
		"Lubricated"	"Dry"			"Lubricated"	"Dry"
1/4-20	2,000	6 ft-lbs	8 ft-lbs	1/4-20	2,850	9 ft-lbs	12 ft-lbs
5/16-18	3,350	13 ft-lbs	18 ft-lbs	5/16-18	4,700	18 ft-lbs	25 ft-lbs
3/8-16	4,950	23 ft-lbs	31 ft-lbs	3/8-16	6,950	32 ft-lbs	44 ft-lbs
7/16-14	6,800	37 ft-lbs	50 ft-lbs	7/16-14	9,600	53 ft-lbs	70 ft-lbs
1/2-13	9,050	57 ft-lbs	75 ft-lbs	1/2-13	12,800	80 ft-lbs	107 ft-lbs
9/16-12	11,600	82 ft-lbs	109 ft-lbs	9/16-12	16,400	115 ft-lbs	154 ft-lbs
5/8-11	14,500	113 ft-lbs	151 ft-lbs	5/8-11	20,300	159 ft-lbs	211 ft-lbs
3/4-10	21,300	200 ft-lbs	266 ft-lbs	3/4-10	30,100	282 ft-lbs	376 ft-lbs
7/8-9	29,435	321 ft-lbs	430 ft-lbs	7/8-9	41,550	454 ft-lbs	606 ft-lbs
1-8	38,600	482 ft-lbs	640 ft-lbs	1-8	54,540	680 ft-lbs	900 ft-lbs



Grade Identification for Metric–Grade 8.8 Bolt



Grade Identification for Metric–Grade 10.9 Bolt

Metric Class 8.8 Torque Values				Metric Class 10.9 Torque Values			
Diameter (mm)	Clamp Loads (lbs)	Tightening Torque		Diameter (mm)	Clamp Loads (lbs)	Tightening Torque	
		"Lubricated"	"Dry"			"Lubricated"	"Dry"
5	1,389	3 ft-lbs	5 ft-lbs	5	1,987	5 ft-lbs	7 ft-lbs
6	1,965	6 ft-lbs	8 ft-lbs	6	2,812	8 ft-lbs	11 ft-lbs
7	2,826	10 ft-lbs	13 ft-lbs	7	4,044	14 ft-lbs	19 ft-lbs
8	3,579	14 ft-lbs	19 ft-lbs	8	5,121	20 ft-lbs	27 ft-lbs
10	5,672	28 ft-lbs	37 ft-lbs	10	8,116	40 ft-lbs	53 ft-lbs
12	8,243	49 ft-lbs	65 ft-lbs	12	11,796	70 ft-lbs	92 ft-lbs
14	11,246	77 ft-lbs	103 ft-lbs	14	16,092	111 ft-lbs	148 ft-lbs
16	15,882	125 ft-lbs	167 ft-lbs	16	21,970	173 ft-lbs	231 ft-lbs
18	19,423	172 ft-lbs	229 ft-lbs	18	26,868	238 ft-lbs	317 ft-lbs
20	24,784	244 ft-lbs	325 ft-lbs	20	34,284	338 ft-lbs	450 ft-lbs

TORQUE SPECIFICATIONS

37° JIC Flare Torque Values			
Turns	Size	Ft-lbs min.max	Assembly Steps
N/A	-02	6-7	<ol style="list-style-type: none"> 1. Make sure the tubing and threads are clean. 2. Lubricate the threads with 10W hydraulic oil. 3. Hand tighten the nut/sleeve to approx. 30 in-lbs. 4. Make alignment marks on the nut and fitting. 5. Tighten to turn or torque specification. 6. When fully tightened, make a 2nd set of alignment marks at the fully tighten positioned. <p>NOTE: Torque values specified are for threads lubricated with 10W hydraulic oil.</p> <p>Over tightening will reduce the clamping force resulting in loss of seal and reduction of flow.</p>
N/A	-03	8-9	
2	-04	11-12	
2	-05	14-15	
1-1/2	-06	18-20	
1-1/2	-08	36-39	
1-1/2	-10	57-63	
1-1/4	-12	79-88	
1	-14	94-103	
1	-16	108-113	
1	-20	127-133	
1	-24	158-167	
1	-32	245-258	

O-Ring Boss Torque Values		
Size	Ft-lbs min.max	Assembly Steps
-02	6-7	<ol style="list-style-type: none"> 1. Verify the port, o-ring, sealing surfaces and threads are clean and free of damage. 2. Lubricate the threads and the o-ring with 10W hydraulic oil. 3. For an adjustable O.R.B., completely back off the lock nut and washer. 4. Hand tighten the fitting until it contacts the port spotface. Point the elbow or tee in the desired direction and hold. 5. Torque to specification. <p>NOTE: Torque values specified are for threads lubricated with 10W hydraulic oil.</p>
-03	8-10	
-04	13-15	
-05	17-21	
-06	22-25	
-08	40-43	
-10	43-57	
-12	68-75	
-14	90-99	
-16	112-123	
-20	146-200	
-24	154-215	
-32	218-290	

MOLDBOARD & A-FRAME ASSEMBLY

1. Position the pivot beam and A-frame near the connecting points at the rear of the blade between the two center support ribs. Insert one 3/4" DIA. x 3" clevis pin through each mounting hole and secure with 1/4" DIA. x 1-1/2" cotter pin.

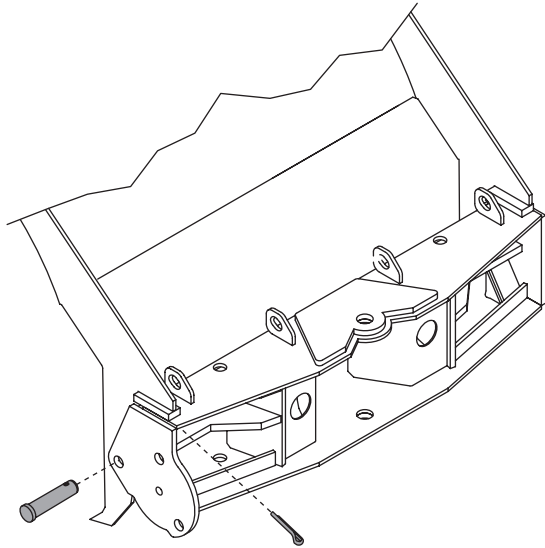

2. Mount the kickstand to the end of the pivot beam (driver side) using the 1/2"-13 x 4-1/2" bolt provided. The spring, bushing and locknut are located on the inside of the pivot beam. Review the diagrams below and to the right. To pivot the kickstand, pull the spring loaded leg out and rotate it until the pin locks into place. Adjust the foot on the stand arm so that the foot is 1/8" from the ground when the A-frame is level and the A-frame mount points are 12-1/2" from the ground. Tighten both of the locknuts on the kickstand.

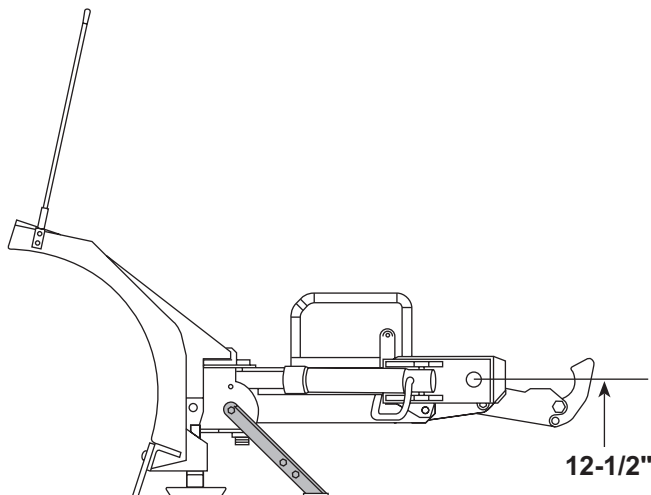
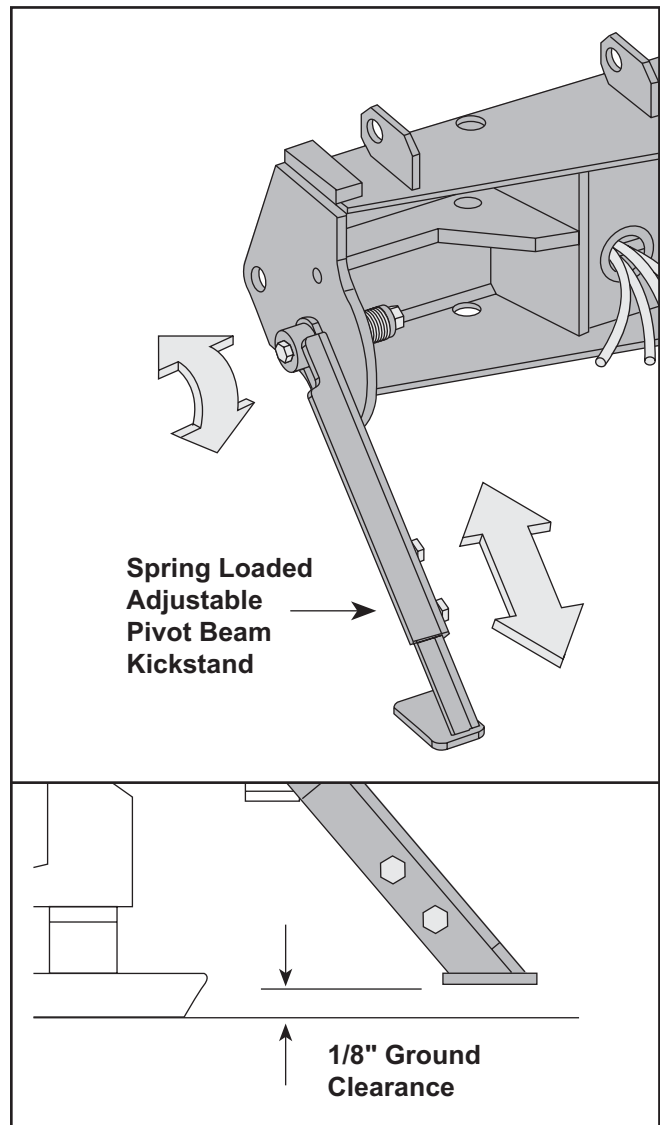

MOLDBOARD & A-FRAME ASSEMBLY

- Position each angle cylinder with the rod end of the cylinder in the pivot beam and the hydraulic hose port facing away from the A-frame. Secure the cylinder to the pivot beam with a 3/4" x 5" clevis pin (**B41051**) and a 1/4" x 1-1/2" cotter pin (**B61357**). Extend each cylinder rod until the cylinder base mounting hole aligns with the hole on the A-frame angle cylinder bracket. Insert another clevis pin and secure it with a cotter pin.
- Remove the dust cap from both of the hydraulic angle cylinder ports and attach one 9/16"-18 x 9/16"-18 90° adjustable elbow O.R.B. adapter (**B60005**) to each port. Each adapter should be angled toward the top of the moldboard. Connect one 3/8" x 24" hydraulic hose (**B60091**) to each angle cylinder adapter. Be careful not to over tighten the hose connections. Route both hoses over the TOP of each cylinder. This will prevent them from hanging or being pinched. Tighten fittings and hoses per torque chart.

- Remove the plastic dust caps from the hydraulic lift cylinder ports. Attach one 9/16"-18 x 9/16"-18 45° adjustable elbow O.R.B. adapter (**B60272**) to the driver's side port (base end) and one 9/16"-18 x 9/16"-18 male O.R.B. connector adapter (**B60007**) to the passenger's side port (rod end). Once the adapters have been installed on the cylinder, connect the hydraulic hoses. Tighten fittings and hoses per torque chart.

NOTE: Position the 45° fitting in the cylinder port so that the hoses install directly in the center of the A-frame access holes. A hose installed too close to the edge of the opening may work itself free with the operation of the lift cylinder and/or movement of the plow.

The 45° adapter receives a 3/8" x 17" hydraulic hose (**B60273**). Connect the 45° angle on the hose to the hydraulic adapter on the cylinder. The male connector adapter receives a 3/8" x 15" hydraulic hose (**B60274**). Connect the 45° end of the hose to the hydraulic adapter on the cylinder. Both hoses should be routed through the triangular openings in the A-frame. Tighten fittings and hoses per torque chart.

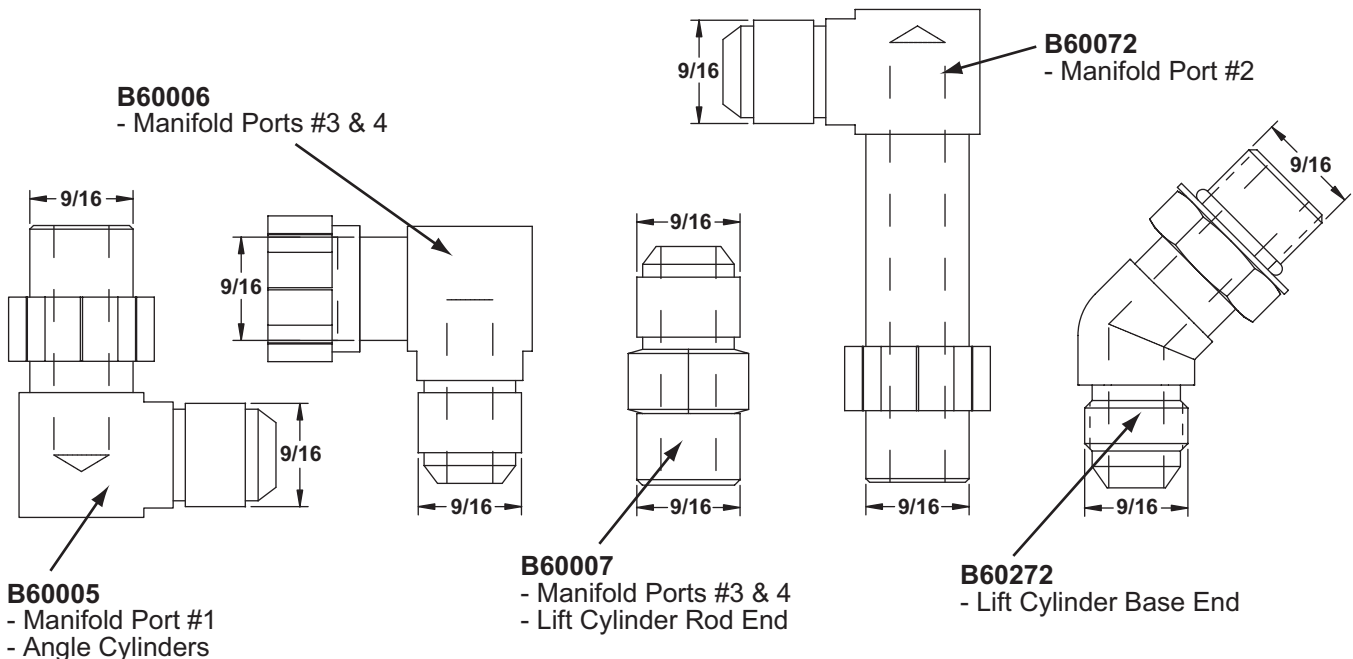

MOLDBOARD & A-FRAME ASSEMBLY

6. Remove the draw latch mount pin, spacer & cotter pin from the draw latch assembly. By removing this pin, the inner draw latch plates can swing free. Remove the inner draw latch plate lift cylinder mount pin. Position the plates on either side of the lift/lower cylinder rod and insert the pin through the plates and cylinder rod. With the cylinder connected to the inner draw latch plates, rotate the draw latch assembly toward the draw latch mount holes on the A-frame. Align the holes in the outer draw latch plate with those of the inner draw latch plates and the A-frame.

NOTE: The A-frame latch, located at the rear/center of the A-frame, should be raised up to insert the draw latch mount pin. Pull the A-frame latch pull pin out and rotate the latch counterclockwise if it is locked into position.

Secure the assembly to the A-frame by replacing the draw latch mount pin, spacer and cotter pin. Reset the A-frame latch so the A-frame latch pull pin locks into place.

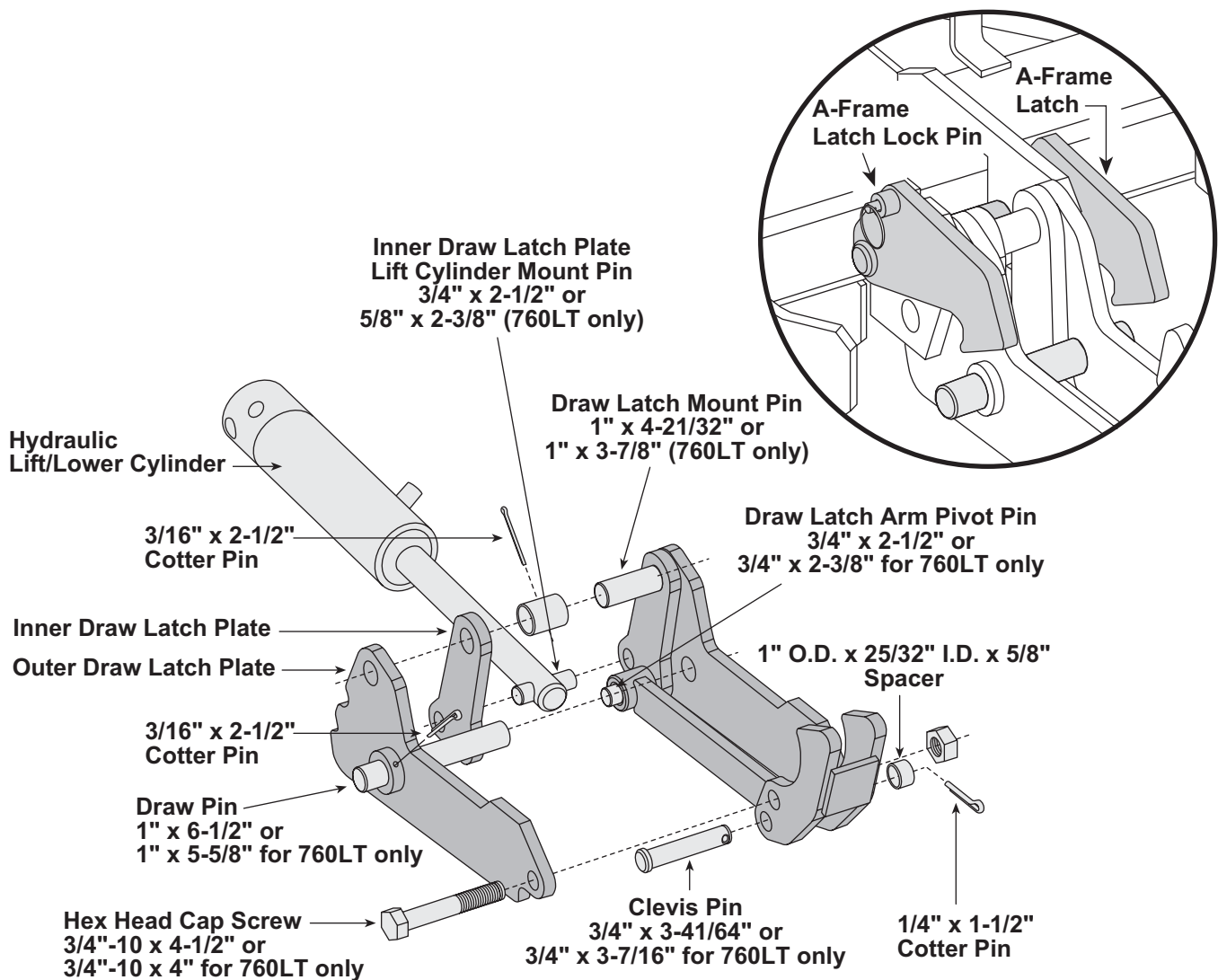

MOLDBOARD & A-FRAME ASSEMBLY

7. Assemble the manifold. The manifold, pump and coil harness have been connected at the factory; however, the manifold contains several components that you will need to install prior to securing the assembly to the A-frame. Each of the hose ports on the manifold is covered with stretch wrap. Remove the wrap and install the appropriate fitting in its respective port. Tighten fittings and hoses per torque chart.

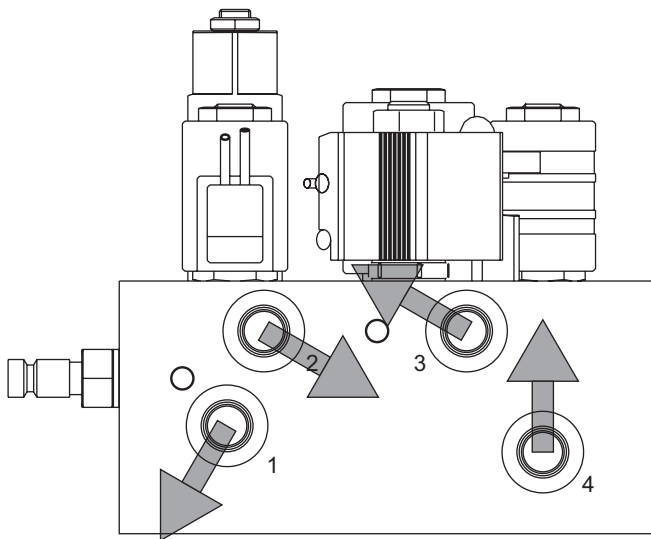

NOTE: The arrows shown on the manifold illustration indicate the direction the 90° adapters should be positioned to receive the hydraulic hoses.

NOTE: DO NOT let any foreign objects enter into the open ports. The valves can become contaminated and greatly hinder the plow's performance. Torque to proper specifications.

NOTE: All ports are identified by a stamped number on the manifold. The numbers also identify the hydraulic functions, which can be referenced on the label under the hydraulic pump and manifold cover.

8. Align the mount holes in the pump with the holes in the hinged bracket, located on the A-frame.

NOTE: Before mounting the pump, angle the hinged bracket as needed and tighten the bracket hardware to lock it in place.

Secure with 3/8"-16 x 3/4" hex head cap screw and 3/8" flat washer through the top mount hole in the bracket and into the pump. Insert 3/8"-16 x 1-3/4" threaded stud with 3/8"-16 locknut through the bottom mount hole in the bracket and into the pump. The threaded stud should bottom out in the pump.

NOTE: When installing the manifold between the mount brackets on the A-frame, hold the manifold at the sides of the block. Never handle the manifold by coils. Doing so can cause a solenoid cartridge to bend, causing the cartridge to stick when activated.

NOTE: A medium strength thread-locking compound should be used on both of the pump mount fasteners.

9. Connect the hydraulic hoses to their respective adapters on the manifold. Hose P/N B60091 Ports #1 & #2, Hose P/N B60273 Port #3 and Hose P/N B60274 Port #4. Tighten hoses per torque chart.

NOTE: Both lift cylinder hoses should be routed through the triangular openings in the A-frame. Position these hoses over the A-frame angle and to their respective manifold ports.

MOLDBOARD & A-FRAME ASSEMBLY

10. Secure the manifold to the A-frame. Remove the washers, split lock washers and cap screws from the manifold and align the mount holes with the A-frame brackets. Properly replace and tighten all hardware.

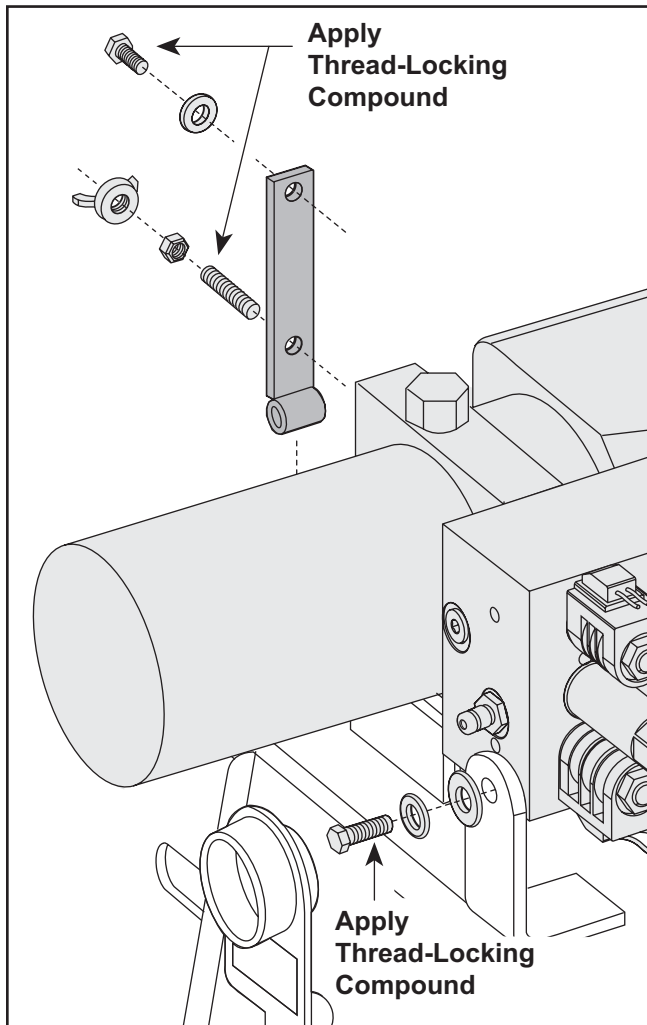

NOTE: A medium strength thread-locking compound should be used to secure the manifold mount fasteners.

11. Hook each extension spring to the receiving holes on the pivot beam and attach the opposite end of the spring to its respective spade bolts. Install the spade bolts through the extension spring mounting angle on the top rear of the blade. Secure each spade bolt by placing one 5/8" flat washer on the bolt and thread one 5/8"-11 nylon insert lock nut. Tighten each lock nut until a piece of paper can pass between the 3rd & 4th coils on the spring.

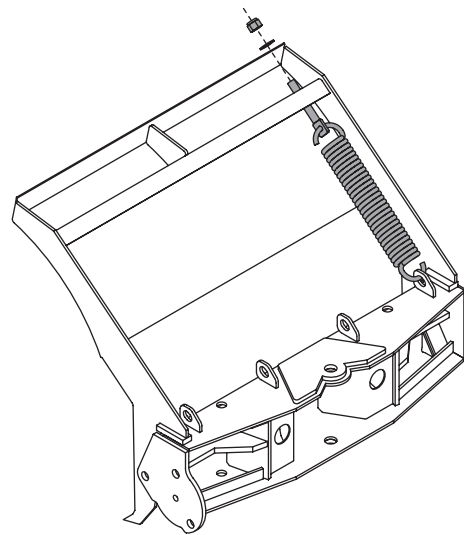

12. Install the blade guides at each end of the moldboard. Insert the cap screw through the holes at the top of the wing reinforcement rib. Tighten all screws with locknuts.

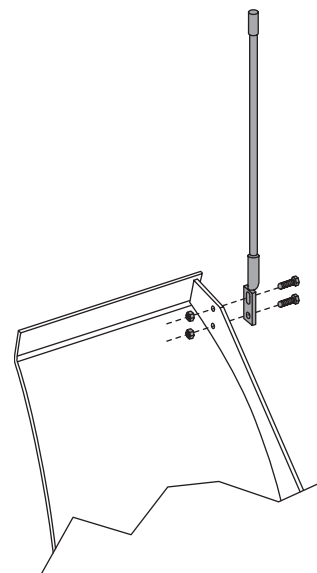

GENERAL SYSTEM SCHEMATICS

B60270 ELECTRICAL SCHEMATIC

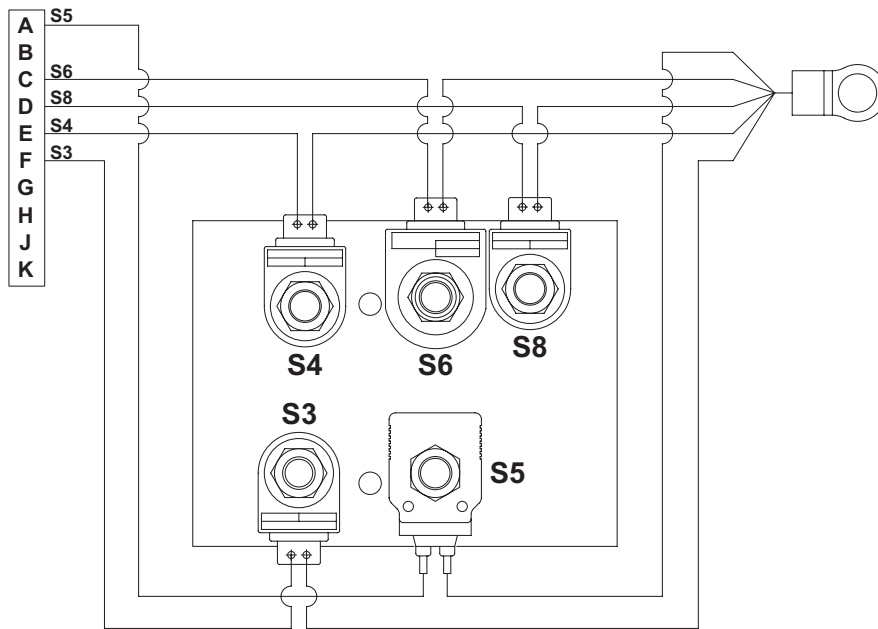

B60270 HYDRAULIC SCHEMATIC

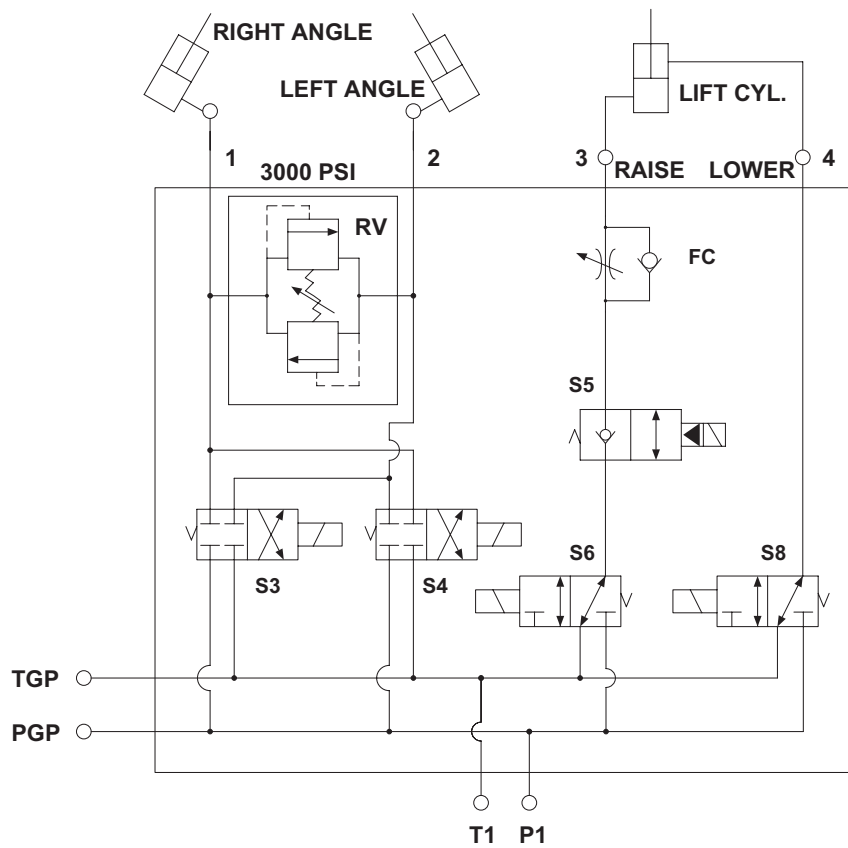

Hydraulic Valve & Hose Port Guide

Models 760LT/760/800/860

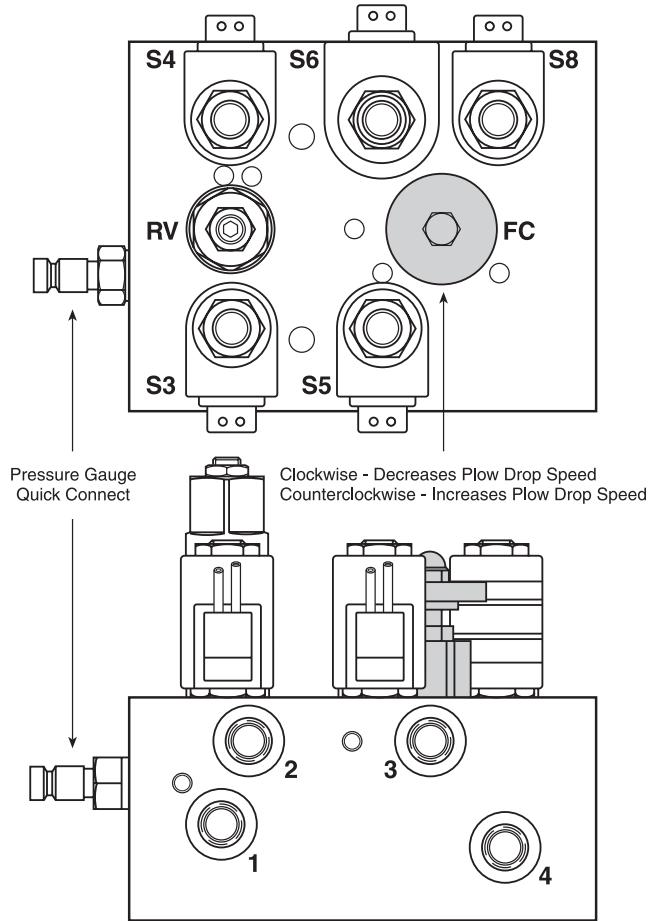

HYDRAULIC HOSES

Port	Function
1	Right Angle - Left Cylinder
2	Left Angle - Right Cylinder
3	Raise - Lift Cylinder (Base)
4	Lower - Lift Cylinder (Rod)

NOTE: Energize the following solenoids for the functions:

S3	Left Angle - Right Cylinder
S4	Right Angle - Left Cylinder
S5	Float
S6	Raise - Lift Cylinder (Base)
S5 & S8	Lower - Lift Cylinder (Rod)
RV	Angle Relief Valve
FC	Variable Flow Control Valve



Calumet, Michigan 49913

BLZ 1054

ELECTRICAL INSTALLATION – SNOWPLOW SIDE

1. Connect the red power wire from the plow harness to the pump motor terminal stud. Hardware provided on pump.
2. Place the 3/8 lock washer, the black ground wire (from the harness) and the red ground wire on the coil harness (from the manifold) over the tapped hole on the pump and secure with 3/8"-16 x 3/4" screw.
3. Remove the nut and washer from the POWER HITCH™ connect/disconnect toggle switch and insert it through the back of the mounting bracket on the A-frame. Align the notches on the switch and bracket. Replace the washer and nut and tighten until the switch is firmly in place. Attach the connector on the plow harness to the switch.

NOTE: Use caution when connecting, switches can break if done forcefully.

4. Attach the connector on the harness to the connector on the coil harness.
5. Position the harness braid in the notch on the switch bracket and secure it with a cable tie.

NOTE: The diode loop harness should be inside of the pump cover.

6. Install the pump & manifold cover by aligning the notches in the cover with the welded bolts on the A-frame brackets. Secure with clamping knob. Verify the cover is positioned over the protective toggle switch hood. Pop the front of the cover on the threaded stud and secure it with the remaining knob.

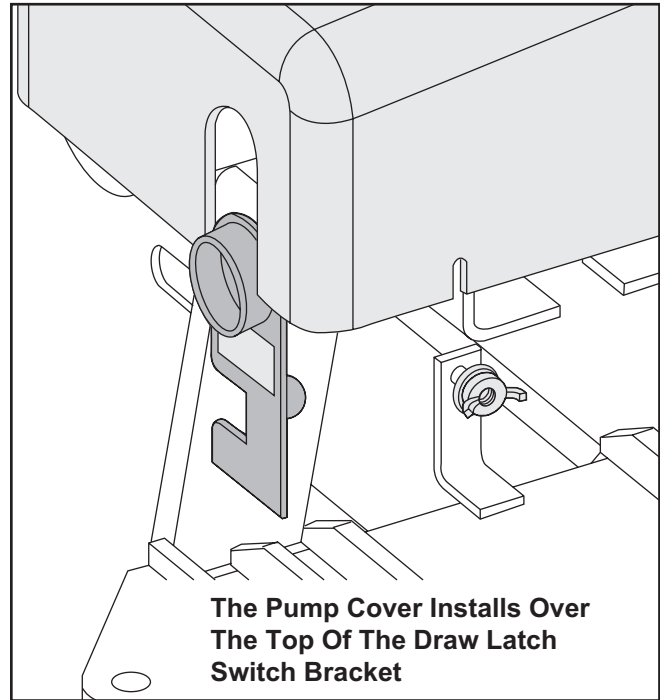

ELECTRICAL SCHEMATICS

BLIZZARD® HARNESS PLUG (VEHICLE) UNIVERSAL 14 + 2 MOLD

PIN NO.	COLOR	FUNCTION	AWG
1	BLACK	GROUND	4
	BLACK	GROUND	18
2	RED	12 VOLT DC (+)	4
3	BROWN/WHITE	PUMP SOLENOID TO RING	18
	BROWN	PUMP SOLENOID TO MOLEX	18
4	RED/WHITE	RIGHT SLIDE BOX EXTEND	18
5	RED/BLACK	RIGHT SLIDE BOX RETRACT	18
6	BLUE/WHITE	LEFT SLIDE BOX EXTEND	18
7	BLUE/BLACK	LEFT SLIDE BOX RETRACT	18
8	BLUE	LEFT ANGLE	18
9	LT. GREEN	RIGHT ANGLE	18
10	WHITE	LIFT	18
11	ORANGE	FLOAT	18
12	N/A	N/A	N/A
13	N/A	N/A	N/A
14	N/A	N/A	N/A
15	PINK/BLACK	12 (+) VDC FUSED	18
16	N/A	N/A	18

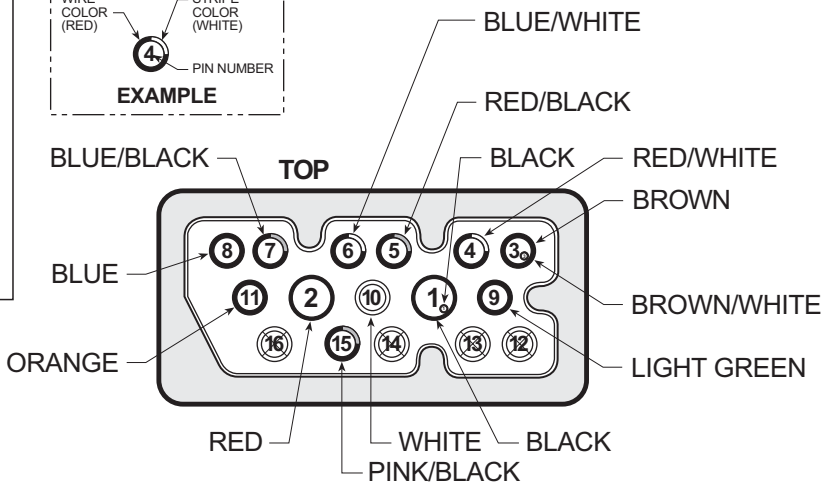
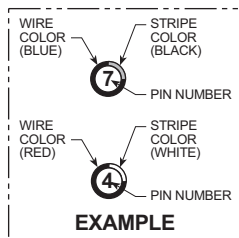
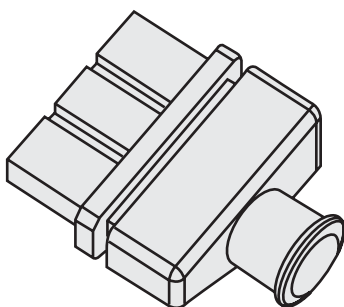

VEHICLE HARNESS PLUG (2005)
FACE VIEW LOOKING AT FEMALE CONNECTOR
FEMALE TERMINALS

BLIZZARD HARNESS PLUG (PLOW)

PIN NO.	COLOR	FUNCTION	AWG
1	BLACK	GROUND	4
	N/A	N/A	N/A
2	RED	12 VOLT DC (+)	4
3	BROWN	PUMP SOLENOID	18
4	RED/WHITE	RIGHT SLIDE BOX EXTEND	18
5	RED/BLACK	RIGHT SLIDE BOX RETRACT	18
6	BLUE/WHITE	LEFT SLIDE BOX EXTEND	18
7	BLUE/BLACK	LEFT SLIDE BOX RETRACT	18
8	BLUE	LEFT ANGLE	18
9	LT. GREEN	RIGHT ANGLE	18
10	WHITE	LIFT	18
	WHITE	LIFT	18
11	ORANGE	FLOAT	18
12	N/A	N/A	N/A
13	N/A	N/A	N/A
14	N/A	N/A	N/A
15	PINK/BLACK	12 (+) VDC FUSED	18
16	N/A	N/A	18

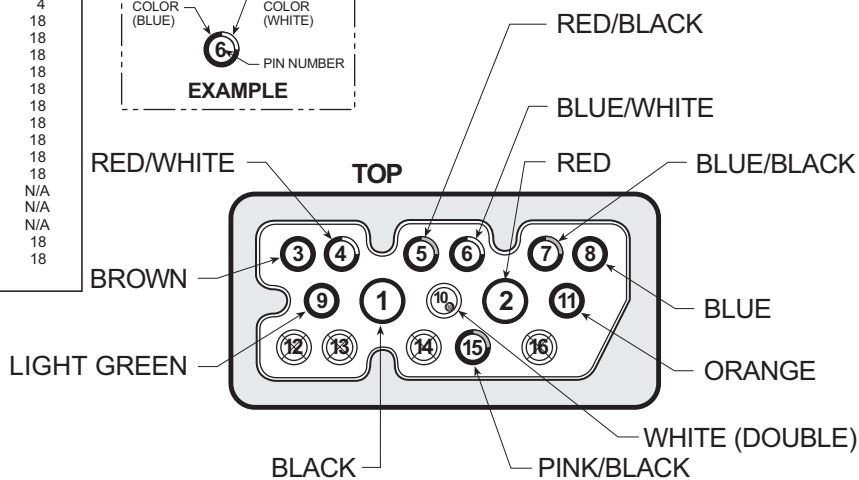
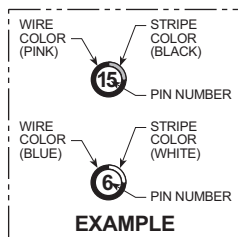
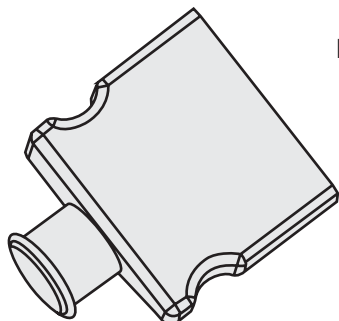

PLOW HARNESS PLUG (2005)
FACE VIEW LOOKING AT MALE CONNECTOR
MALE TERMINALS

ELECTRICAL SCHEMATICS – SNOWPLOW SIDE

PLOW HARNESS (B62039)

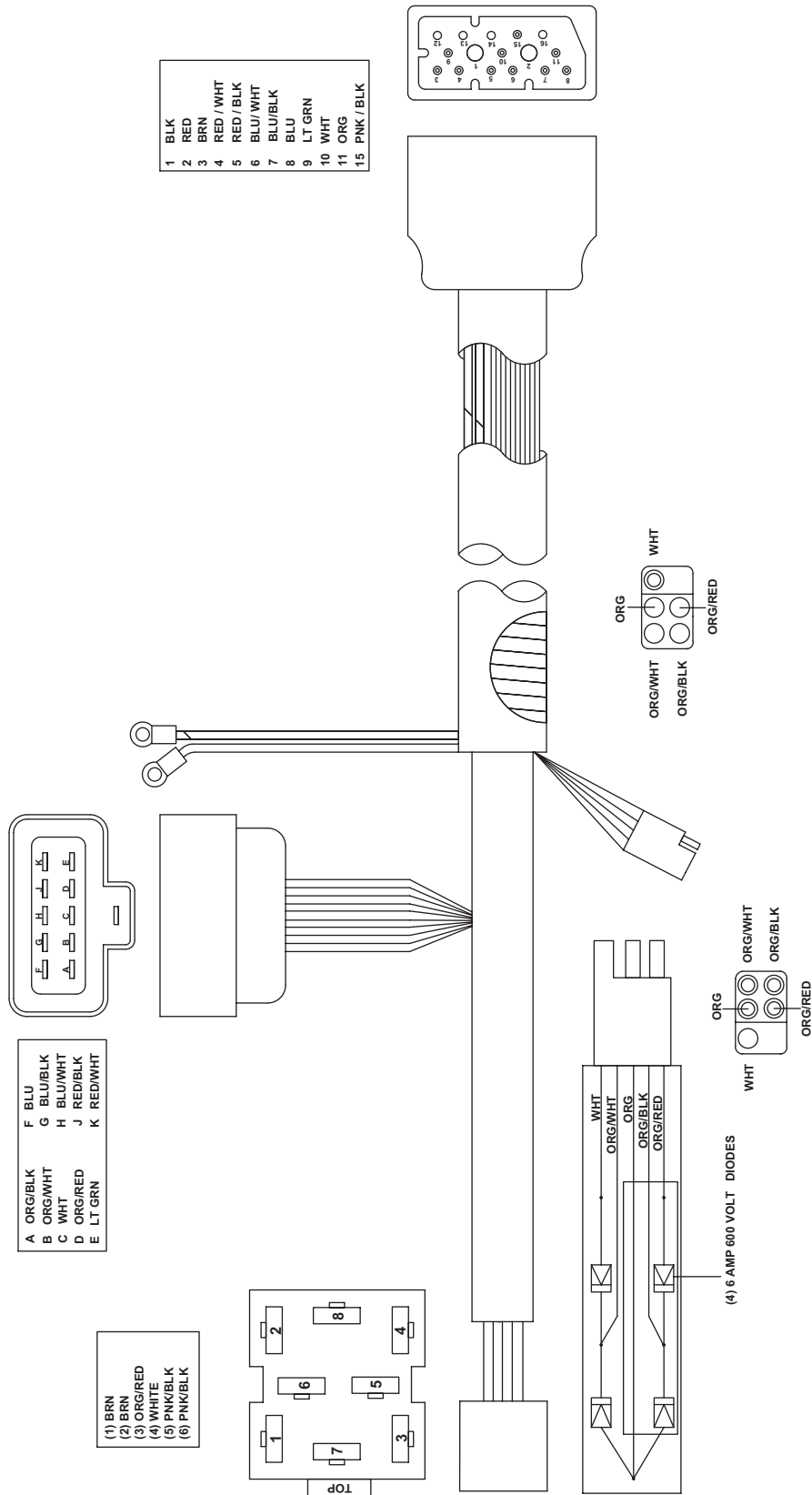

ELECTRICAL SCHEMATICS – SNOWPLOW SIDE

PLOW WIRE HARNESS SCHEMATIC (B62039)

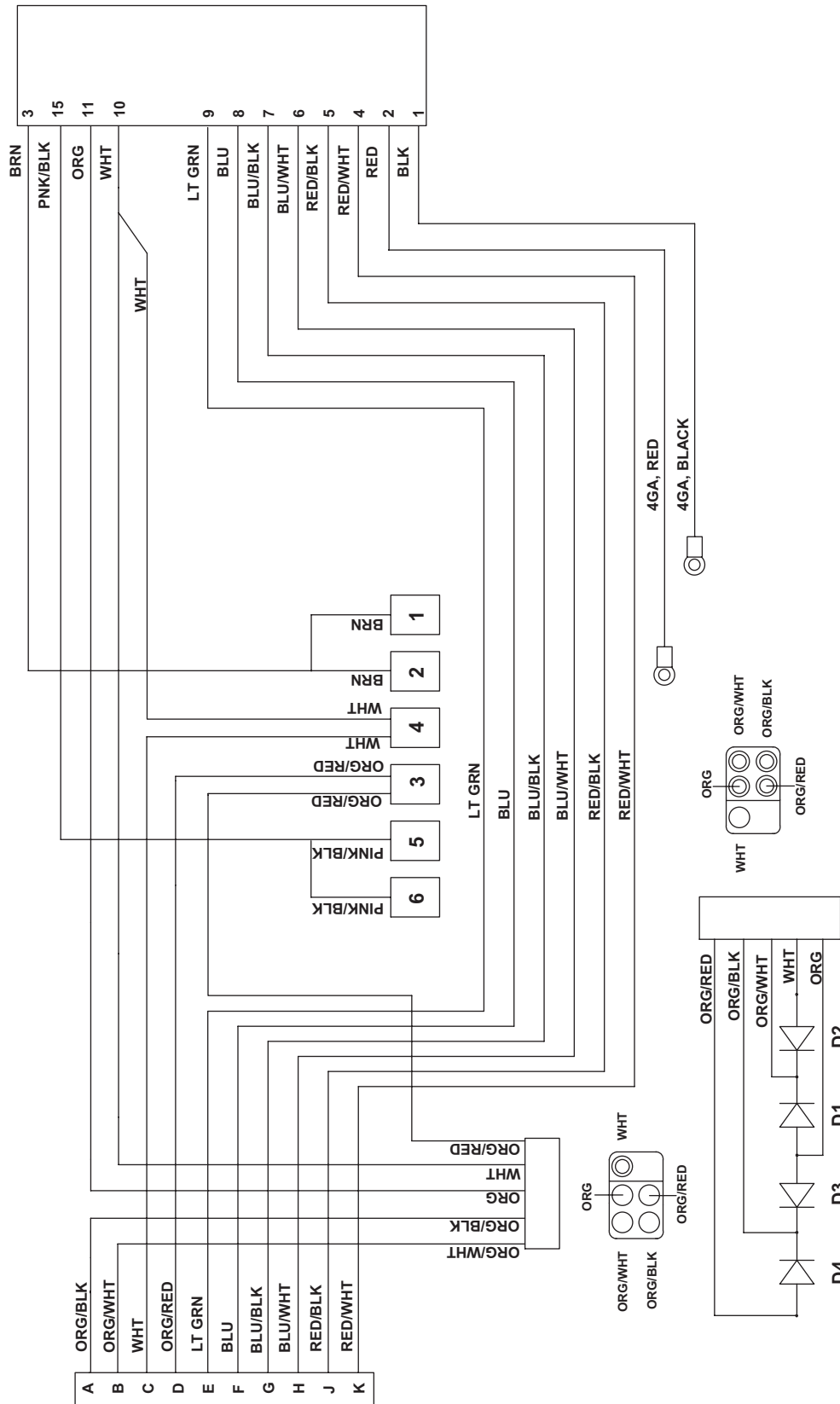

ELECTRICAL INSTALLATION – VEHICLE SIDE

⚠ CAUTION

Before drilling any holes, check the selected area for wires, hoses or other obstructions.

1. With the large plug on the electrical harness placed near the tow hook, under the bumper, route the harness over the driver-side fender well and to the fire wall. Insert the connector end of the harness through an existing hole in the fire wall and into the vehicle cab. If an access hole does not exist, drill an appropriately sized hole through the fire wall in a convenient location away from sharp edges and hot or moving parts.

NOTE: Keep the plow plug and vehicle connector pins lubricated with a liberal amount of dielectric grease. Always replace the protective weather caps when the plow is disconnected from the vehicle.

2. Attach the power contactor (solenoid) to the driver's side wheel well or engine fan guard using 12-14 x 3/4" self-drilling screws.

NOTE: Some model vehicles provide mounting locations for accessory components.

Always mount the solenoid with the terminals facing up, for extended solenoid life. Connect the 24" black ground wire to either small terminal on the solenoid and attach the opposite end to the vehicle with a self-drilling screw. Cut the brown/white pump activation wire on the harness

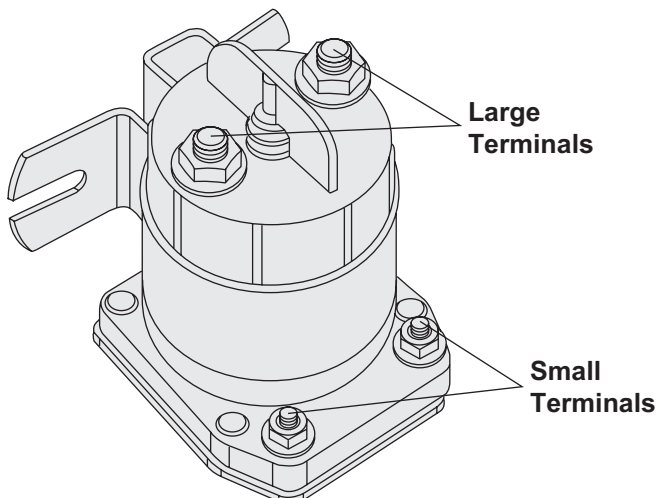

(HD Solenoid Shown)

to length. Strip the end of the harness, and crimp the eyelet terminal onto it. Attach the eyelet to the remaining small terminal on the contactor. Secure it with the hardware provided on the solenoid.

NOTE: Do not fasten the harness to areas that come in contact with moving engine parts or possess extreme heat. The harness could become tangled and/or melt causing electrical failure and vehicle damage.

3. Connect the vehicle harness ground wire to the negative terminal on the vehicle's battery. Cut the wire to length, and strip the end of the wire. Crimp and solder a 3/8" ring terminal on the wire.

NOTE: The harness should be secured to the vehicle prior to taking the necessary measurement.

Measure the distance needed for the power wire to reach the solenoid. Strip the wire, then crimp and solder an end ring terminal to it. Connect the power wire to either large terminal on the solenoid.

4. Strip both ends of the remaining length of red wire, then attach and solder an end ring terminal to both. Connect one end of the wire to the open terminal on the solenoid and the remaining end to the positive terminal on the battery.
5. Position the main lighting harness with both of the truck light connectors near each truck headlight and the plow light connectors near the grille of the vehicle.
6. Plug the headlight ground/relay connector from the vehicle harness into the connector on the main lighting harness. Securely mount the relay receptacles to the vehicle with the terminal wires facing down and the relays facing up. Installing the relays in this position will allow moisture to drain from the relay.

ELECTRICAL INSTALLATION – VEHICLE SIDE

- Remove the front signal light assembly from both sides of the vehicle. On the driver side, feed the violet (turn light) and gray (run light) wires from the main lighting harness through the opening in the signal light housing. Use a test light or ohm meter to determine the proper wires in the vehicle's electrical system to splice into. Position one end of the turn or run light wire into the splice lock connector, and attach the vehicle wire into the opposite side. Complete the splice by pinching both wires together and locking the connector. Repeat the splice procedure for the remaining wire.
- Repeat Step 7 for passenger side using the pink (turn light) and gray (run light) wires.
- Connect the vehicle headlights to the main lighting harness using a light conversion harness kit. Due to differences in the construction of the kits, and the various make and model vehicles BLIZZARD® snowplows are installed on, a light conversion kit is not packaged with your snowplow. Contact your local BLIZZARD dealer to obtain the appropriate conversion harness kit for your vehicle.
- Secure the braided harness to the vehicle. Safely route all harnesses around the engine components and attach them to the vehicle with cable ties. Extend the plow headlight connectors, from the main lighting harness, through the grille of the vehicle and position the harness power plug and weather cap near the bumper. Cable tie the plug to the vehicle bumper or tow hook to keep the harness from hanging too low.

⚠ CAUTION

Do not alter, modify or install additional components in shaded areas of the following illustration. Failure to comply may interfere with air bag deployment or cause injury to operator in an accident.

- Install the remainder of the vehicle wire harness to the interior of the cab. Find an accessible location for the plow headlight toggle switch and bracket

under the dashboard. When choosing a location for your switch, it should be mounted in easy reach of the vehicle operator and not restricting access to vehicle controls or vehicle instrumentation. Do not mount the switch in areas prohibited by the vehicle manufacturer for crash worthiness. See the vehicle's body builders book, owner's manual or service manual for details. The shaded areas in the illustration below show the most commonly restricted areas.

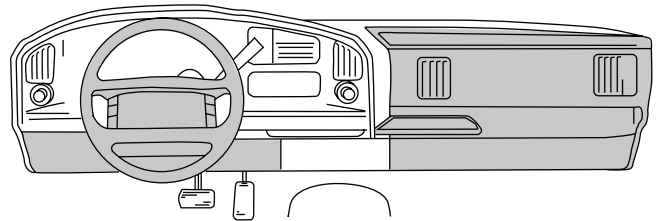

Install the headlight bracket using two self-drilling screws. Insert the toggle switch through the bracket and secure it with the hardware provided. Plug both of the switch leads into the toggle switch.

NOTE: Both terminals should be inserted into the spades on the same side of the switch. One terminal should be positioned in the middle spade.

Plug both 2-pin connectors together and this will connect the toggle switch to the vehicle wire harness. See illustration below.

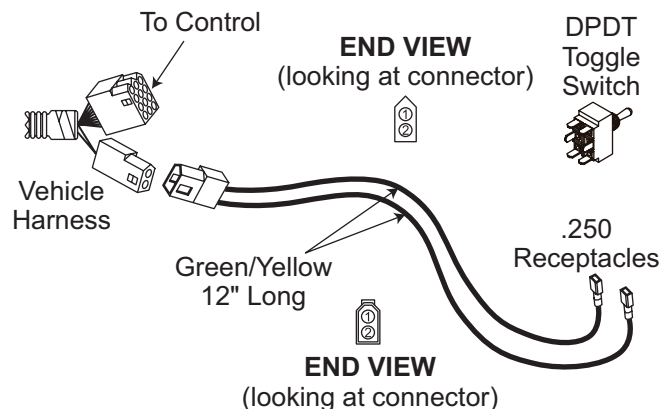

ELECTRICAL INSTALLATION – VEHICLE SIDE

12. Connect the power wire (with 15AMP FUSE) to a switched power source with a minimum of 15 amps.

NOTE: The red power wire MUST be fused and switched on and off with ignition.

Secure all loose wires under the dash.

13. Install the light tower. Position the arms into the receiving pockets located on the undercarriage. Each pocket has a lock pin that secures both light tower arms. Pull out and twist each handle to temporarily unlock the pins. Place the light tower into the pockets and relock the pins. See your local BLIZZARD dealer for complete installation instructions for your vehicle undercarriage.
14. Install the plow headlights. Align one headlight stud on the light tower tube with the mounting hole and insert the threaded stud through each. Secure the headlight with one 1/2" galvanized washer (neoprene facing up), one 7/16" external tooth lock washer and hex nut.

NOTE: All snowplows are shipped with two caps that install on the ends of the light tower.

After adding a liberal amount of dielectric grease, connect the terminals from the plow lights to the terminals on the main lighting harness.

15. **If using a joystick control**, align the mount holes on the joystick control with the holes located on the mount pedestal.

NOTE: The radius on the pedestal should face the dashboard.

Secure the joystick to the pedestal with the 8-32 x 3/4" machine screws provided. Slide the hook and look fastener strap through the slots cut in the pedestal. The D-ring should be located on the side opposite of the radius. Wrap the strap around the bench and fasten.

16. Connect the white power connector from the vehicle wire harness to the connector on the control station. The power switch should be in the "OFF" position.

NOTE: The operation of the draw latch can only be controlled when the switch on the control is in the "POWER HITCH™" position and the "RAISE/LOWER" rocker switch on the A-frame is in the neutral (center) position.

17. After completing the mechanical and electrical installations, test all snowplow and lighting functions before attempting to drive or plow.

Joystick Control

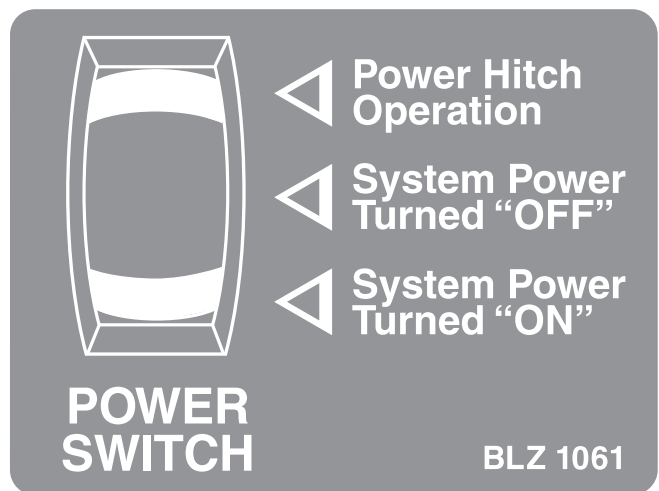

Touchpad Control

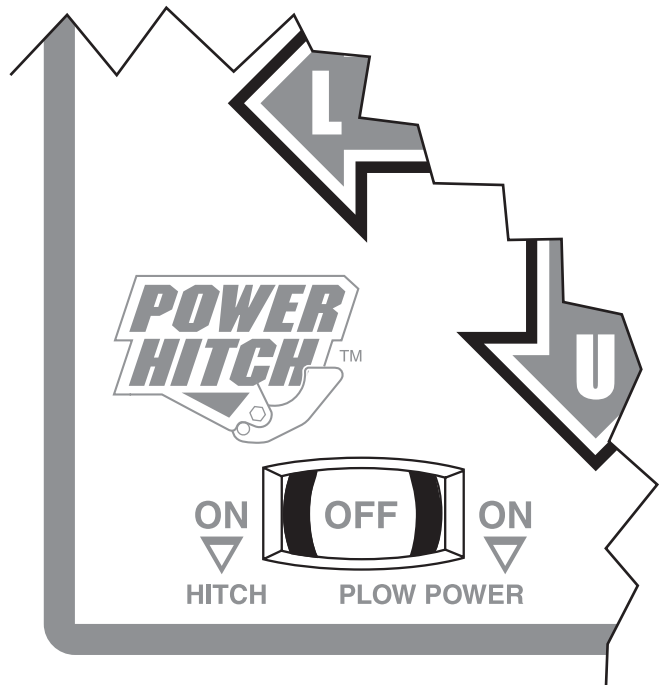

ELECTRICAL SCHEMATICS – VEHICLE SIDE

VEHICLE HARNESS (2005)

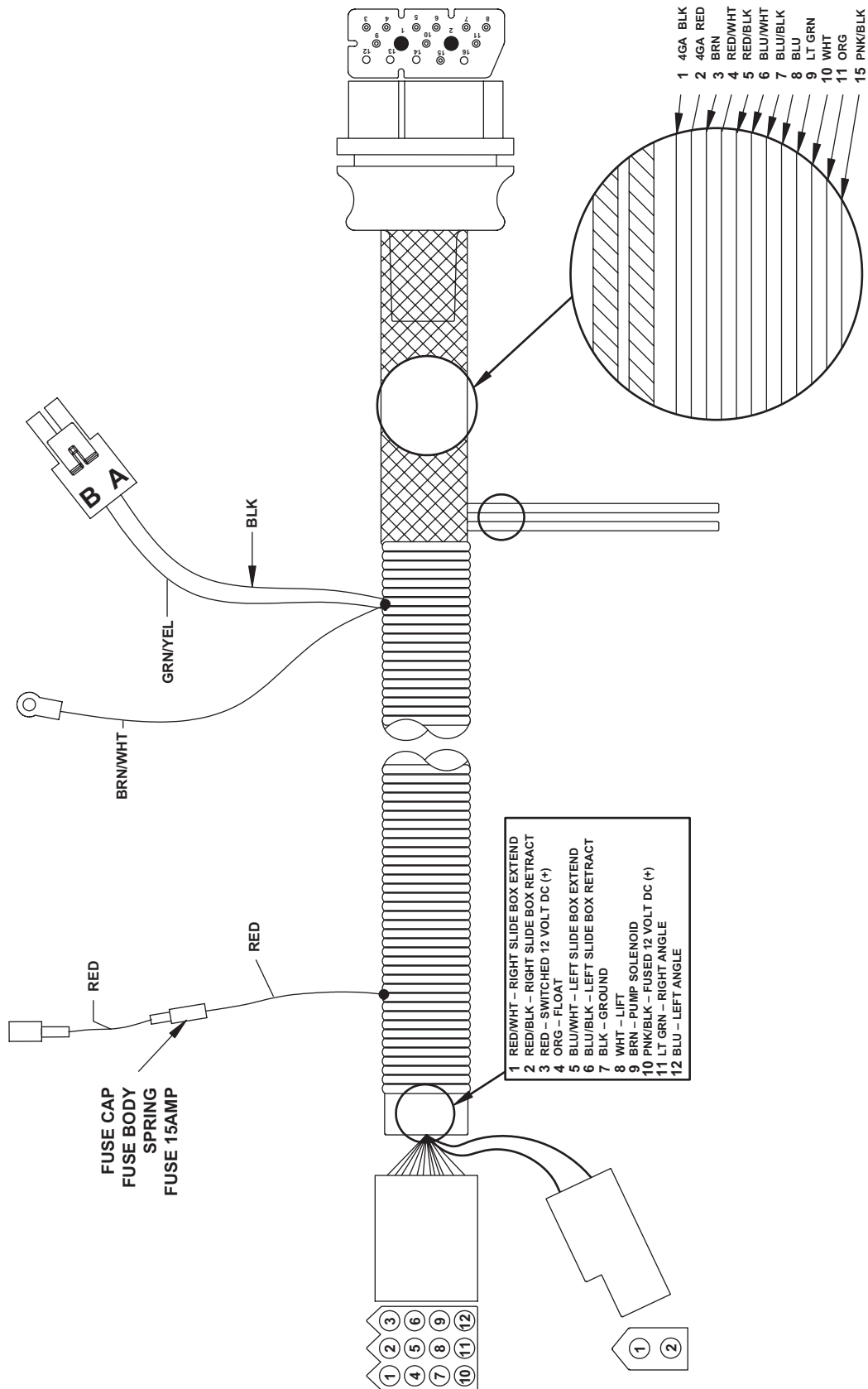

ELECTRICAL SCHEMATICS – VEHICLE SIDE

VEHICLE HARNESS SCHEMATIC (2005)

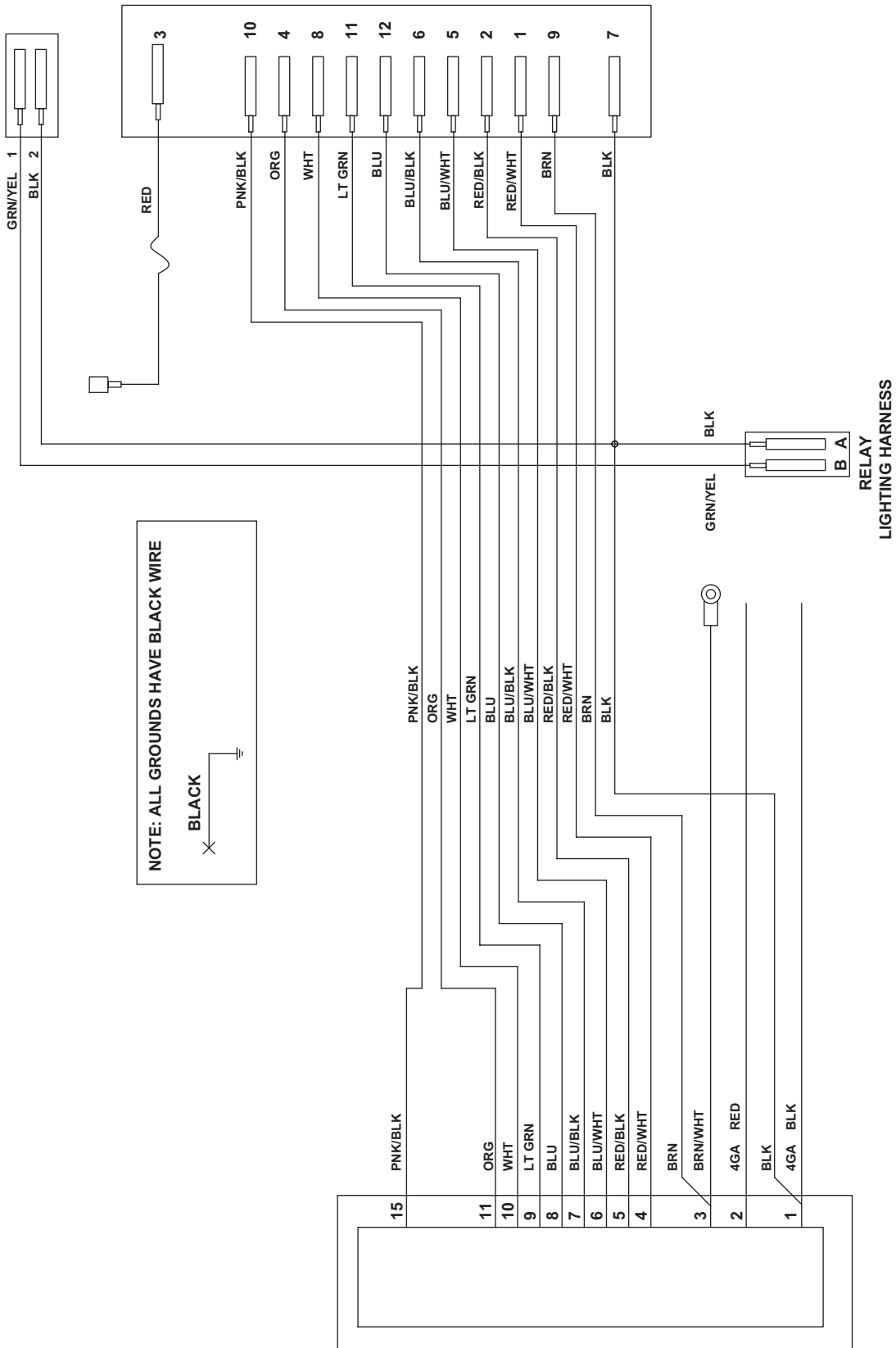

ELECTRICAL SCHEMATICS – VEHICLE SIDE

MAIN LIGHTING HARNESS (2005)

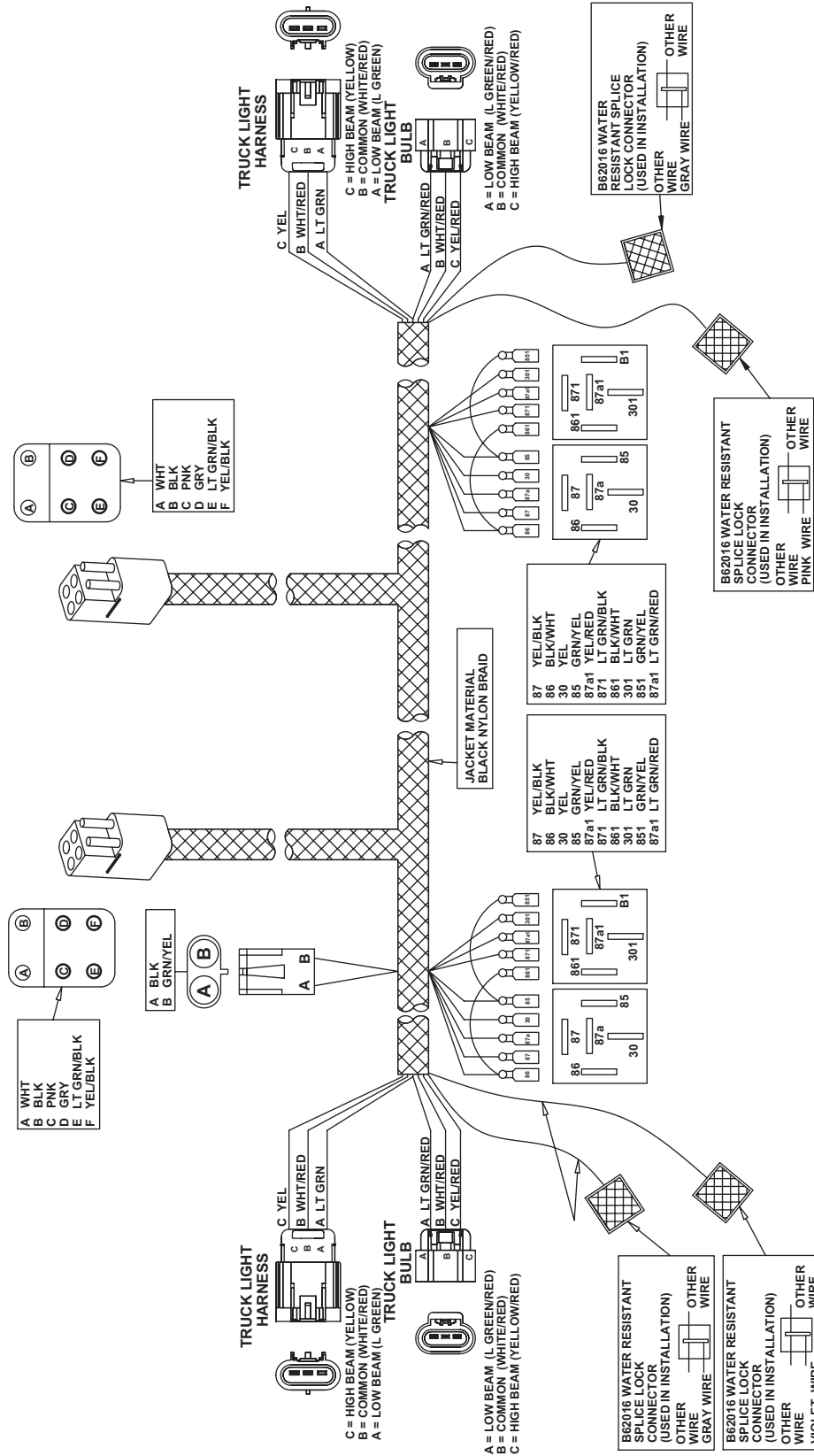

ELECTRICAL SCHEMATICS – VEHICLE SIDE

MAIN LIGHTING HARNESS SCHEMATIC (2005)

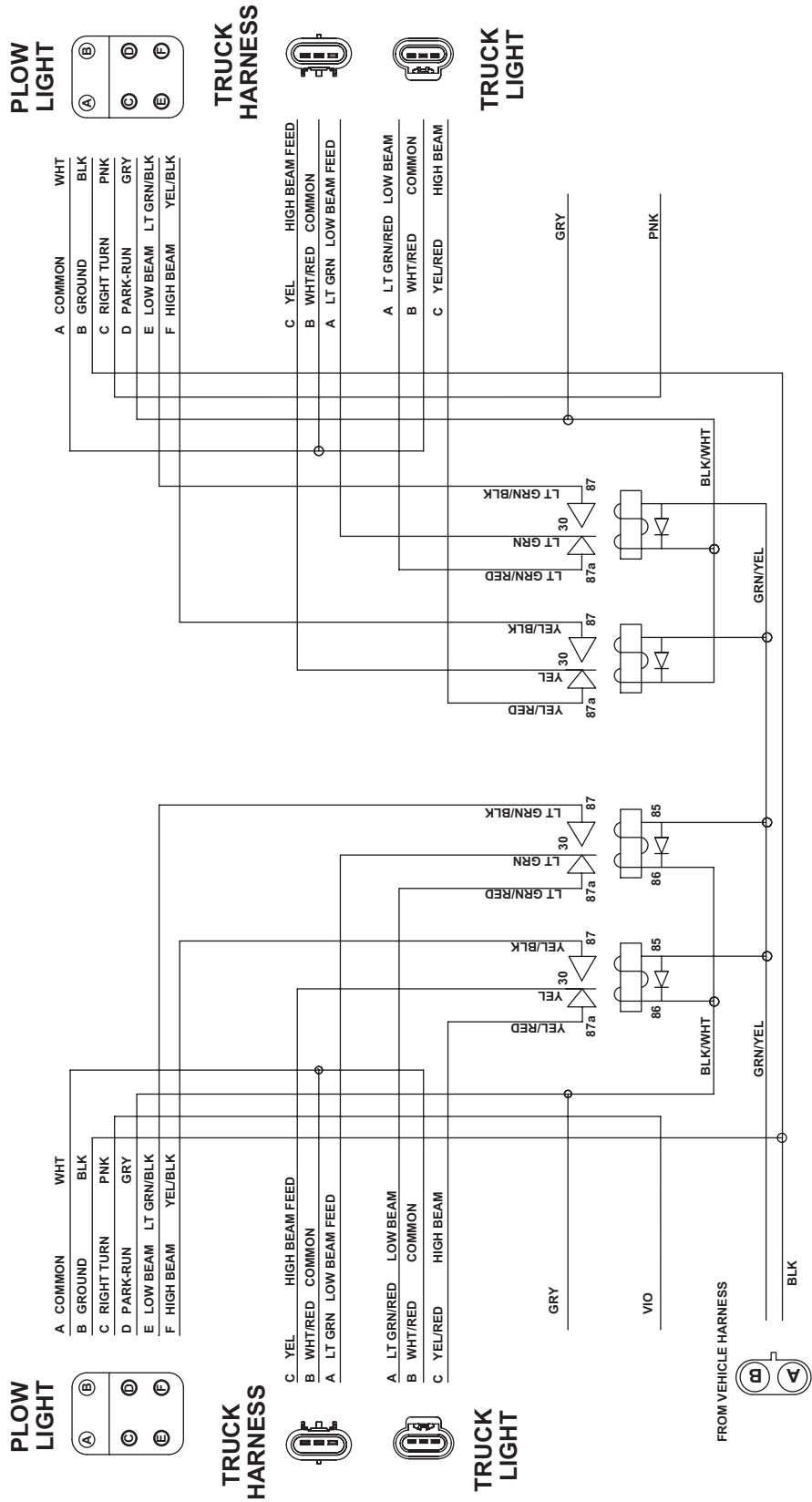

POWER HITCH™ SYSTEM INSTRUCTIONS

Prior to operating your straight blade snowplow, review the Mounting and Dismounting Instructions label on the back of the driver's side moldboard.

NOTE: If at any time the Mounting and Dismounting Instructions label, or any other label attached to your snowplow become illegible, promptly replace them.

MOUNT INSTRUCTIONS

STEP #1

CAUTION: KEEP FINGERS AWAY! POWER HITCH RAISES BEHIND UNDERCARRIAGE PUSH BEAM.

- Kickstand should be in the lowered position.
- Slowly drive vehicle forward until the push beam receiver mount points contact the A-frame mount bushings.
- Turn POWER HITCH OPERATION switch (on plow control) to the "ON" position.
- Connect plow and vehicle electrical harnesses.

DISMOUNT INSTRUCTIONS

STEP #1

CAUTION: KEEP FINGERS AWAY! POWER HITCH LOWERS FROM UNDERCARRIAGE PUSH BEAM.

- With the plow fully raised, lower the kickstand.
- Lower plow on a flat, level surface. Turn vehicle ignition off.
- Remove hitch pins from the A-frame and undercarriage.
- Turn vehicle ignition on.
- Verify POWER HITCH OPERATION switch (on plow control) is in the "ON" position.

STEP #2

- Pull A-frame latch lock pin out and lower the latch over the draw pin.
- Push and hold the CONNECT/DISCONNECT switch upward. The Power Hitch will engage the back of the push beam and pull the plow into the push beam receiver mount points on the vehicle.
- Insert both hitch pins and secure each with a hair pin cotter.
- Lower Power Hitch to relieve tension on the A-frame latch. Raise the A-frame latch into its locked position. Raise plow to the full up position.
- Raise kickstand until it locks into place. The plow is now properly mounted.

STEP #2

CAUTION: KEEP FINGERS AWAY FROM PLOW & TRUCK MOUNTING POINTS!

- Push and hold the CONNECT/DISCONNECT switch downward. The Power Hitch will disengage from behind the undercarriage push beam and lower.
- Disconnect plow and vehicle electrical harnesses. Install weather caps.
- Turn SYSTEM POWER (on plow control) to the "OFF" position.
- Slowly back vehicle away from plow.

BLZ 1077

TESTING YOUR SNOWPLOW

1. Fill the hydraulic pump reservoir with BLIZZARD® SNOWPLOW RAPID ACTION HYDRAULIC OIL until it is approximately 3/4" from the top of the tank. Replace the cap on the reservoir. Remove the weather caps from each of the plow and vehicle harnesses and connect the plugs. Start the vehicle and turn the power switch on the control station in the cab to the "ON" position.



⚠ WARNING

You can die or be seriously injured. Keep hands and feet away from hitch mechanism and snowplow blade when operating the POWER HITCH™ arm. The action of the arm moves the snowplow toward the vehicle and into position for proper attachment.

2. To raise the POWER HITCH™ arm on the snowplow, turn the power switch on the control station to the "UP" or "ON" position. Push and hold the toggle switch on the A-frame upward into the "CONNECT" position. Notice the action of the fluid in the reservoir. By activating the initial hydraulic function, the fluid begins to fill the system. Push and hold the toggle switch in the "DISCONNECT" position, the POWER HITCH arm will lower. Refill the reservoir until the fluid is approximately 3/4" from the top of the tank.

3. Align the POWER HITCH arm on the A-frame below the pushbeam, with the receiver plates in line with the receiver plates on the undercarriage. Pull out the A-frame latch pin and rotate the A-frame latch clockwise until the latch is resting on the draw pin. Move the snowplow in position by activating the POWER HITCH connect switch and release.

The POWER HITCH arm will rise until it hits the pushbeam and the draw latch fingers will pull the plow into the vehicle. The receiver plates on the plow and vehicle are now positively aligned. Insert the two hitch pins through the mounting holes on the A-frame and secure each with one hair pin cotter.

After the two hitch pins are inserted through the A-frame, lower the POWER HITCH arm using the toggle switch on the A-frame. Rotate the A-frame latch counterclockwise until the A-frame latch lock pin can be reinserted. Fully reinserting the A-frame latch lock pin will lock the A-frame latch in place for transport or plowing snow. (See below.)

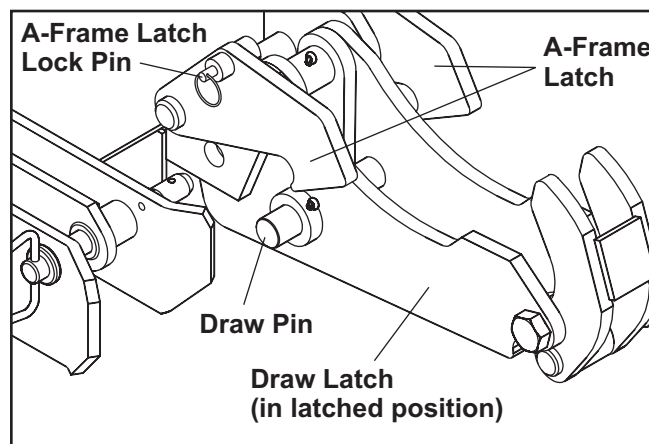

TESTING YOUR SNOWPLOW

- Return to the interior of the vehicle. Test the remaining functions of the snowplow. The system power on the control should be in the "ON" position. Raise the plow to its maximum height by pulling the joystick back (or down) or pressing the "U" button on the touchpad. Angle the snowplow to the left by moving the joystick toward the "L" (left angle) on the label or pressing the "L" button on the touchpad. If the plow function is slow or delayed, the hydraulic fluid is filling the cylinder and replacing the air in the system. Test the remaining functions of the snowplow. To lower the plow to the ground, push the joystick ahead (or up) or push the "D" button on the touchpad.

NOTE: The float function is activated when the joystick is pushed ahead (or up) into the "lower" position or the "D" button is pressed on the touchpad and held there for an additional .5 sec after the blade contacts the ground. The LED float light (touchpad only) will come on when the snowplow is in float mode.

Angle the snowplow to the right by moving the joystick toward the "R" (right angle) on the label or pressing the "R" button on the touchpad. Check the fluid level in the reservoir and fill to 3/4" from the top of the tank if needed.

- Check for oil leaks around the manifold, pump, hydraulic hoses and all cylinders. If there are any leaks, turn off the power switch on the control and shut off the vehicle engine. Then, tighten any loose connections and/or fittings. Restart the vehicle, cycle all blade controls, then check to see if all the leaks have been stopped after shutting off the control power switch and shutting down the vehicle.
- Check that the vehicle and plow headlights are in proper working condition including the turn signals.

(No LED Float Light or Indicator Light)

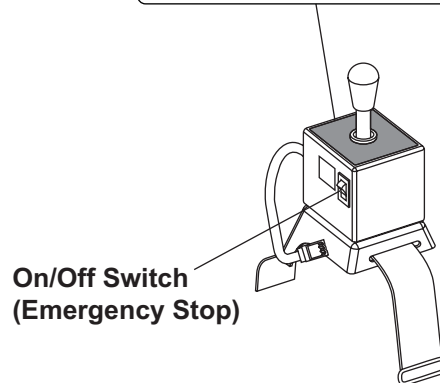

LED Float Light

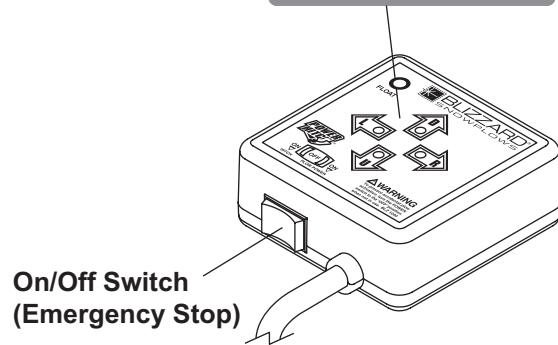
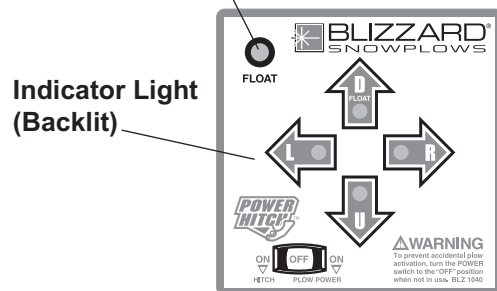

HEADLIGHT AIMING

Fully tighten headlight fasteners once correct visual aim is achieved.

1. Place vehicle on a level surface 25 feet in front of a matte-white screen, such as a garage door. The screen should be perpendicular both to the ground and to the vehicle centerline.
 2. The vehicle should be equipped for normal operation. The snowplow blade should be in place and in raised position. Below are steps listed by the Society of Automotive Engineers (SAE) pertinent to headlight aiming in specification #SAE J599d.
 3. Prepare vehicle for headlight aim or inspection. Before checking headlight aim, the inspector will:
 - a. Remove ice or mud from under fenders.
 - b. Set tire inflation pressures to the values specified on vehicle information label.
 - c. Check springs for sag or broken leaves.
 - d. See that there is no load in the vehicle other than the driver and ballast as specified in the Undercarriage Selection Guide.
 - e. Check functioning of any automatic vehicle leveling systems and specific manufacturer's instructions pertaining to vehicle preparation for headlight aiming.
 - f. Clean lenses.
 - g. Check for bulb burnout and proper beam switching.
 - h. Stabilize suspension by rocking vehicle sideways.
4. Mark (or tape) the vertical centerline of the snowplow headlights and the vertical centerline of the vehicle on the screen. Mark the horizontal centerline of the snowplow headlights on the screen (distance from ground to snowplow headlight centers).
 5. Align the top edge of the high intensity zone of the snowplow lower beam below the horizontal centerline and the left edge of the high intensity zone on the vertical centerline for each snowplow headlight. (Refer to diagram below.)

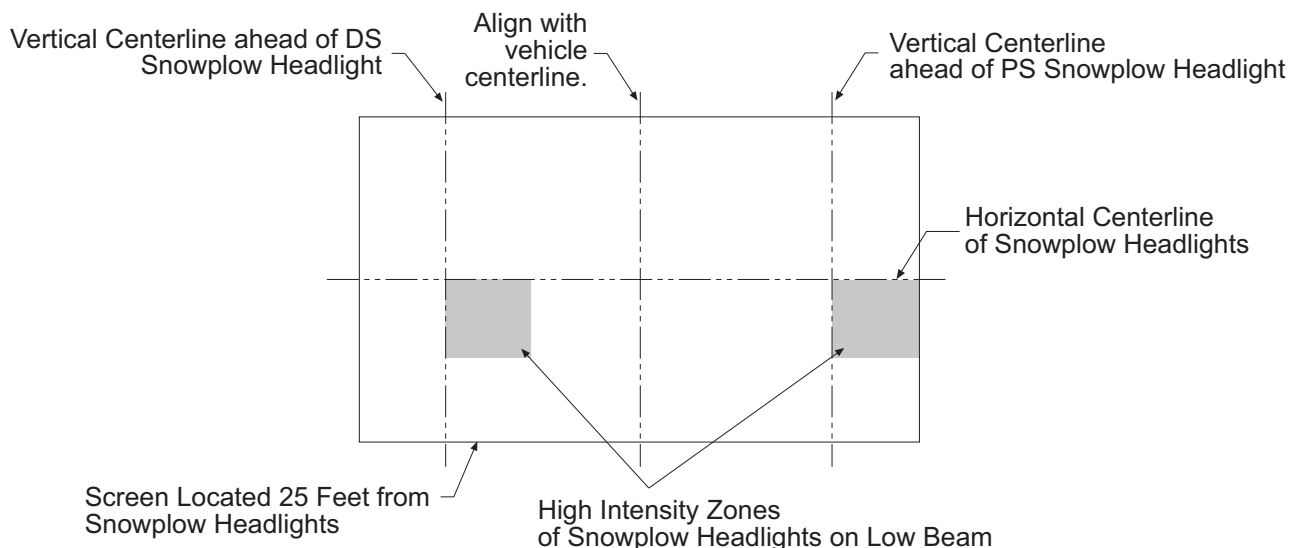

MAINTENANCE

Maintenance	Periodically	Yearly
Check fasteners for tightness. Torque to specifications.	X	
Check hoses for wear and leaks.	X	
Check cylinders for leaks; inspect rod ends for corrosion & pitting	X	
Lubricate all exposed cylinder rod ends with liquid white lithium grease to prevent corrosion.		X
Check cutting edges and plow shoes for wear. <i>NOTE: Do not discard plow shoe washers, these should be retained for different shoe adjustments.</i>	X	
Clean and lubricate all electrical plugs and connections with dielectric grease. Clean and install all dust caps prior to storing.	X	X
Lubricate all pins and bushings, inner slide box and A-frame latch with NLGI Grade 2 multi-purpose lithium complex grease with molybdenum (MPGM) to maintain consistent operation	X	X
Clean and paint all scratches or exposed metal with BLIZZARD® touch-up paint	X	X
Check the hydraulic oil level. Fill with fluid to 3/4" from the top of the reservoir. Do not exceed this level. Never mix different types of fluid.	X	
Remove and properly discard the fluid from the pump reservoir. Clean the pump filter and replace the hydraulic oil to within 3/4" from the top of the reservoir. Changing the fluid annually will prolong the life of your pump and manifold. Never mix different types of hydraulic oil.		X
Check the trip spring adjustment. Properly adjusted tension will allow a sheet of paper to pass between the 3rd and 4th coils of the spring.	X	
Clean snow & ice build-up from the pump and manifold cover.	X	
Pressure wash and dry the entire snowplow prior to storing		X
Cover the snowplow with a tarp if stored outside. This will protect your plow from sun fading and inclement weather which can lead to accelerated corrosion.		X

REMOVING FROM STORAGE

1. Perform all regular maintenance.
2. Replace the hydraulic oil in the pump reservoir. Prolonged storage could result in condensation build-up.
3. Follow the mounting procedure on the POWER HITCH™ label.
4. Initiate all of the functions. Monitor the fluid level in the reservoir and fill to 3/4" from the top of the tank as necessary.
5. Adjust the snowplow headlights as needed.

LIFTING

To lift and move this snowplow, attach chain fall grab hooks to outside pivot beam area shown. Always follow recommended lift warnings and procedures. See following page for snowplow weights and dimensions.

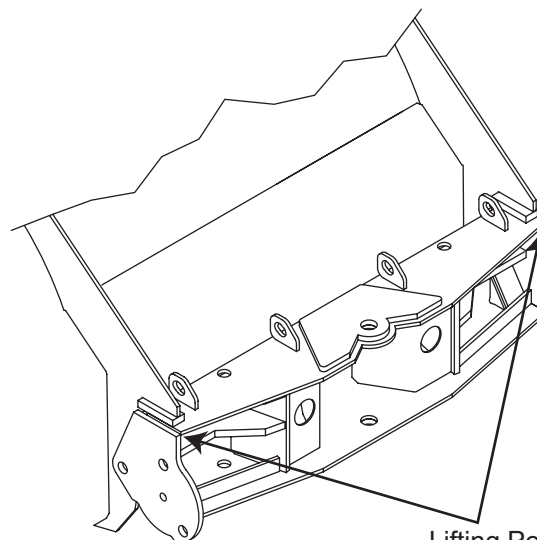

Lifting Points
(both sides)

TECHNICAL SPECIFICATIONS

Part	Specification	760LT	760HD	800HD	860HD
Moldboard	Length	90" (7'6")	90" (7'6")	96" (8')	102" (8'6")
	Thickness	12 gauge			
	Height	29"	31"		
	Reinforcement	4 ribs @ 3/16"	6 ribs @ 1/4"		
	Cutting Edge (1080)	3/8" x 6"	1/2" x 6"		
	Finish	Powder Coat White			
	Trip Mechanism	(3) 3/8" hooked extension	(4) 3/8" hooked extension		
A-Frame	Material	Rectangular Tube & Channel Type			
	Hitch Pins	3/4" x 6" Yellow Zinc			
	Finish	Powder Coat Black			
Pump	Construction	Steel Housing w/Clear Plastic Tank			
	Type	Internal Gear Pump			
	Size	2.5cc			
	Motor	12V Starter			
	Weight	32 lb.			
	Mount	A-frame Install w/hex head screws			
	Reservoir Capacity	2 qts.			
Manifold	Construction	Red Anodized Aluminum			
	Valves	Electro-hydraulic cartridge			
Cylinders	<i>Angle Cylinders</i>	2			
	Stroke	9-3/8"	10"		
	Ram Diameter	1-3/4"			
	Bore Diameter	2"			
	<i>Raise/Lower Cylinders</i>	1			
	Stroke	4-5/8"			
	Ram Diameter	1-1/4"			
Plow Headlights	Type	2-1/2"			
	Measurements	3"			
	Housing	Low profile w/ turn signals			
	Bulb Type	12"W x 5"H x 5-1/4"D			
	Switch Type	Plastic Composite			
Plow Specs.	Weight*	578 lbs.	752 lbs.	769 lbs.	778 lbs.
	Amperage Draw**	145A	135A		
	Adjustable Plow Shoes	(2) Std.	(2) Heavy-Duty Cast Steel		
	Mount Mechanism	Hydraulic Power Switch			
	Control Station	Joystick or Touchpad			

* Weight does not include undercarriage.

** Amperage Draw specifications are based on snowplow lift operation, at a shop temperature of 65°F, using Blizzard Rapid Action Hydraulic Oil. Amperage will vary with temperature, oil viscosity and meter accuracy. Deadheading a plow function will result in significantly increased amperage.

TROUBLESHOOTING

Problem	Cause	Solution
Pump will not run.	Plow harness may not be properly connected to the vehicle harness.	Verify the harnesses are properly connected.
	Power or ground cables to the battery, pump or solenoid may not be properly connected.	Properly connect all cables. Clean and lubricate with dielectric grease. If power does not resume, check the continuity of all cables to find the break.
Pump will not run, power to the solenoid.	The black ground wire and brown/white activation wire on the solenoid are not properly connected.	Properly connect both cables. Test for power by initiating any control function except the float. <i>NOTE: The POWER rocker switch must be in the "ON" position to properly test any plow function.</i> If the solenoid is grounded and no power exists, diagnose the plow & truck harnesses.
Pump will not run with power to the solenoid. Brown/white activation wire and ground are properly connected.	The red, hot wire to the pump motor is not properly connected.	Connect red wire and check the black ground wire. If problem is not resolved, the solenoid could be inoperable or the pump motor may be worn. Replace the solenoid if there is no power to the pump. Replace the pump motor if it is receiving power.
Pump will not turn off. Do not allow the pump motor to run continuously. Unplug the harness until the solenoid can be tested or a BLIZZARD® Dealer can diagnose the problem.	Solenoid may be damaged.	Disconnect the brown/white activation wire from the solenoid. If the problem is not resolved, replace the solenoid.
	Short in the control or wire harness.	Disconnect the control in the cab. If the pump turns off, there is a short in the electrical system.
Pump runs but plow functions are slow.	Fluid level in the pump reservoir is low. Fluid is leaking.	Add fluid to within 3/4" from the top of the tank. Check for leaks around the pump, manifold and cylinders.
	System pressure may be set too low. Increasing the pressure excessively will increase the amperage draw. This could damage the vehicle harness.	Adjust the pressure. Remove the hex cap on top of the pump and turn the screw clockwise. Proper system pressure should be set at 2400PSI. Test functions and repeat procedure as needed.
	Amperage from the vehicle's alternator is too low.	Repair or replace vehicle alternator. System amperage draw is 135A(145A for 760LT) at 1500PSI.
	Pump filter may be clogged.	Remove the pump tank and thoroughly clean the filter.
A-frame latch will not move.	Draw latch is binding the A-frame latch.	Lower the draw latch to relieve binding on the A-frame latch and reposition the A-frame latch as needed.
Plow will not lift. Pump works properly.	Control station in the cab may not be properly connected	Connect the power connector from the control to the vehicle harness.
	A-frame latch is in the (down) locked position.	Lift the A-frame latch into the raised position.
	Diode loop harness may be corroded or could have failed.	Clean diode loop harness thoroughly and/or replace.
	Coils on the manifold may be damaged.	Remove the S6 coil from the cartridge valve. Position a screwdriver inside of the coil and push the draw latch connect/disconnect toggle switch upward. The screwdriver should be magnetically drawn to the coil. Replace the coil if there is no action.
Plow will not lift with magnification to the S6 coil.	Hydraulic lock in the manifold. This occurs if the voltage is too low on the coils –should be 10 volts.	Loosen cartridge valve S6 to relieve pressure and retighten. DO NOT OVER TIGHTEN! Valves should be torqued to a maximum of 24 ft-lbs.
	Solenoid cartridge valve may be contaminated.	Remove any foreign objects that may be obstructing proper valve operation. Replace if not operating properly after cleaning.

TROUBLESHOOTING

Problem	Cause	Solution
Plow will not stay angled when plowing.	The angle pressure relief valve is set too low. <i>NOTE: Increasing the pressure relief valve will cause damage to your plow. Do not set the pressure relief greater than 3000 PSI.</i>	Check the pressure relief by testing the valve inline with the cylinder. Attach a tee fitting to the angle cylinder hydraulic adapter and connect the hose and pressure gauge to the tee. <i>NOTE: The setting should not exceed 3000PSI.</i>
Plow will not angle, pump works.	Review all probable causes above.	<i>NOTE: Verify coils S3 & S4 for angle functions.</i>
Plow lowers too slow.	Variable flow control valve is not adjusted properly.	⚠ WARNING: Snowplow can fall suddenly. You can die or be seriously injured. Drop snowplow to ground before adjusting flow control. Turn flow control valve counterclockwise in small increments and test.
	Review all probable causes for plow will not lift	Verify S5 coil (float) or S5 & S8 coils (disconnect) for magnetism.
Plow drops sporadically.	Variable flow control valve is opened too far.	⚠ WARNING: Snowplow can fall suddenly. You can die or be seriously injured. Drop snowplow to ground before adjusting flow control. Turn clockwise 1/16 of a turn and test.
Headlights will not switch from the vehicle to the snowplow.	No power or ground to the headlight relay.	Verify the headlight/ground relay connector is connected. If the connector is properly attached replace the headlight relay(s).

NOTES

MOLDBOARD & WING PARTS – ALL MODELS

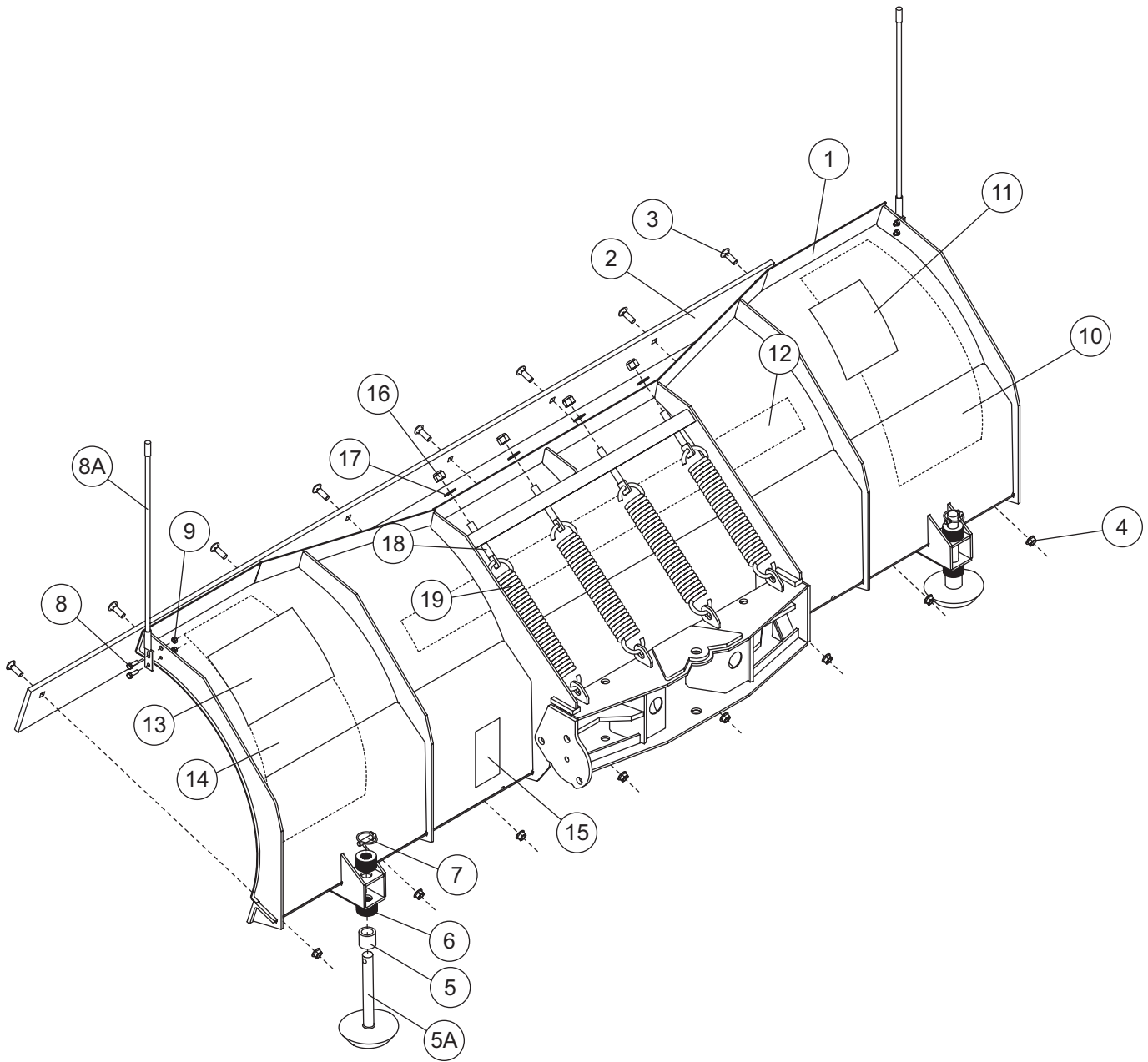

MOLDBOARD & WING PARTS – ALL MODELS

Item	Part	Qty				Description
		760LT	760HD	800HD	860HD	
1	B81006	1	–	–	–	Moldboard Weldment
	B84006	–	1	–	–	
	B80006	–	–	1	–	
	B80020	–	–	–	1	
2	B61165	1	–	–	–	Cutting Edge
	B61168	–	1	–	–	
	B61164	–	–	1	–	
	B61528	–	–	–	1	
3	B61196	8	8	8	8	Bolt, Carriage, 1/2"-13 x 1-1/2" Gr8 P
4	B61365	8	8	8	8	Nut, 1/2"-13 Flanged Lock Z
5A	B61098	2	–	–	–	Plow Shoe Assembly, Standard (7-3/4" Shaft) Includes Item 5–7
	B61220	–	2	2	2	Plow Shoe Assembly, Heavy-Duty (8-3/8" Shaft) Includes Item 5–7
5	B61102	2	2	2	2	Spacer, 1-1/8" I.D., 1-5/8" O.D. x 1-1/2" YZ
6	B61101	36	36	36	36	Washer, 1" Flat YZ
7	B61103	1	1	1	1	Pin, Linch, 7/16" x 1-3/4" YZ
8A	B61049	1	1	1	1	Plow Guide Assembly (2) Includes Item 8 & 9
8	B61051	4	4	4	4	Screw, 5/16"-18 x 1" HHCS Gr5 Z
9	B61052	4	4	4	4	Nut, 5/16"-18 Nylock Z
10	B61176	1	1	–	–	Decal, Passenger's Side Moldboard
	B61178	–	–	1	1	
11	59900	1	1	1	1	Label, Warning/Caution
12	B63163	1	1	1	1	Decal, Center Moldboard
13	B63167	1	1	1	1	Label, POWER HITCH™ Mounting & Dismounting (Blz1077)
14	B61177	1	1	–	–	Decal, Driver's Side Moldboard
	B61179	–	–	1	1	
15	29256	1	1	1	1	Label, Warning! Crush Hazard
16	B61188	3	4	4	4	Nut, Nylock, 5/8"-11 Type NE
17	B61064	3	4	4	4	Washer, 5/8" SAE Hardened YZ
18	B61201	3	4	4	4	Bolt, Spade, 5/8"-11 x 4-3/8" Grade 8 Z
19	B61167	3	–	–	–	Spring, Extension, 12-15/16" O.A.L. x 2-3/8" O.D. x 3/8"
	B61099	–	4	4	4	

A-FRAME & PIVOT BEAM PARTS – ALL MODELS

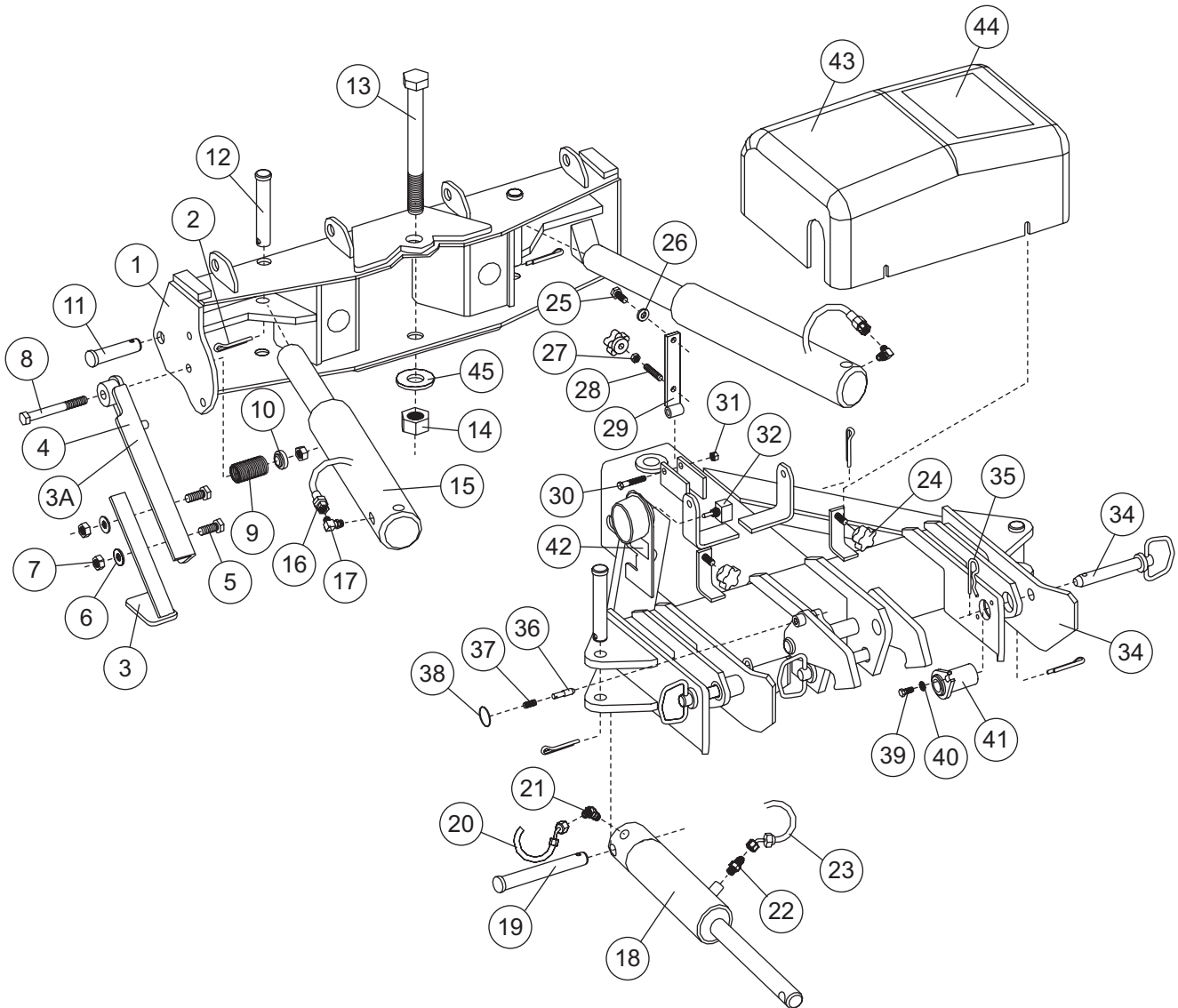

Item	Part	Qty		Description
		760LT	HD	
1	B52153	1	–	Pivot Beam Weldment
	B41041	–	1	
2	B61357	7	7	Pin, Cotter, 1/4" x 1-1/2" Z

A-FRAME & PIVOT BEAM PARTS – ALL MODELS

Item	Part	Qty		Description
		760LT	HD	
3A	B41039	1	1	Kickstand Assembly Includes Item 3–10
3	B41047	1	1	Kickstand Foot Weldment
4	B41038	1	1	Kickstand Leg Weldment
5	B61057	2	2	Screw, 1/2"-13 x 1-1/4" HHCS Gr8 YZ
6	B61026	2	2	Washer, 1/2" Flat SAE Hardened
7	B52153	3	3	Nut, 1/2"-13 Top Lock Z
8	B61152	1	1	Screw, 1/2"-13 x 4-1/2" HHCS Gr8 YZ
9	B61293	1	1	Spring, Compression, 2" O.A.L. x 1.101" O.D. x 0.207" Dia.
10	B41037	1	1	Bushing, 1.13" O.D. x 0.53" I.D. x 3/8" Stepped
11	B50069	2	2	Pin, 3/4"Dia. x 3" Clevis YZ
12	B41051	4	4	Pin, 3/4"Dia. x 5" Clevis YZ
13	B61331	1	–	Screw, 1"-8 x 8-1/2" HHCS Gr8 P
	B61330	–	1	Screw, 1"-8 x 9" HHCS Gr8 P
14	B61008	1	1	Nut, 1"-8 Top Lock Z
15	B60065	2	–	Hydraulic Cylinder, Plow Angle
	B60029	–	2	
16	B60091	2	2	Hydraulic Hose, 3/8" x 24" Plow Angle (Ports #1 & #2)
17	B60005	2	2	Hydraulic Adapter, 9/16"-18 x 9/16"-18 90° Adjustable Elbow O.R.B.
18	B60236	1	–	Hydraulic Cylinder, Plow Raise/Lower
	B60255	–	1	
19	B82061	1	–	Pin, 5/8" Dia. x 5-3/4" Clevis YZ
	B40124	–	1	
20	B60273	1	1	Hyd. Hose (Port #3), Straight/45°, 3/8" x 17" - Raise/Lower, Extend
21	B60272	1	1	Hydraulic Adapter, 9/16"-18 x 9/16"-18 45° Adjustable Elbow O.R.B.
22	B60007	1	1	Hydraulic Adapter, 9/16"-18 x 9/16"-18 Male O.R.B.
23	B60274	1	1	Hyd. Hose (Port #4), Straight/45°, 3/8" x 15" - Raise/Lower, Retract
24	B61628	3	3	Knob, 3/8-16 Nylock Clamping
25	B61012	2	2	Screw, 3/8"-16 x 3/4" HHCS Gr8 YZ
26	B61016	1	1	Washer, 3/8" SAE Hardened
27	B61014	1	1	Nut, 3/8"-16 Jam Nylock Z, Type NTE
28	B61629	1	1	Stud, 3/8"-16 x 2-1/8" Threaded
29	B40004	1	1	Hinge Weldment, Pump Mount
30	B61218	1	1	Screw, 3/8"-16 x 2" HHCS Gr8 YZ
31	B61034	1	1	Nut, 3/8"-16 Top Lock Z
32	B62038	1	1	Switch, Toggle, DPDT, (On)-Off-(On), 16 Amps, 115V AC
33	B52154	1	–	A-Frame Weldment
	B52150	–	1	
34	B61426	3	3	Pin, 3/4" x 6" Hitch YZ
35	B61105	3	3	Pin, 9/64" DIA. x 2-11/16" Hair Cotter Z
36	B40079	1	1	Pin, 3/8" DIA. x 1-3/4" SS
37	B61000	1	1	Spring, 0.94" O.A.F.L. x 0.36" O.D., 0.029" Wire Dia. Compression SS
38	B61309	1	1	Ring, Standard Split SS
39	B61312	2	2	Screw, 5/16"-18 x 3/4" HHCS Gr8 YZ
40	B61011	2	2	Washer, 5/16" Split Lock YZ High-Alloy
41	B40088	2	2	Bushing, A-frame Pivot, Replaceable
42	B61295	1	1	Label, POWER HITCH™ Connect/Disconnect Switch (Blz1037)
43	B40119	1	1	Cover, Hyd. Pump & Manifold
44	B63099	1	1	Label, Hyd. Hose Identification Guide (BLZ1054)
45	B61203	1	1	Washer, 1" SAE

POWER UNIT PARTS – ALL MODELS

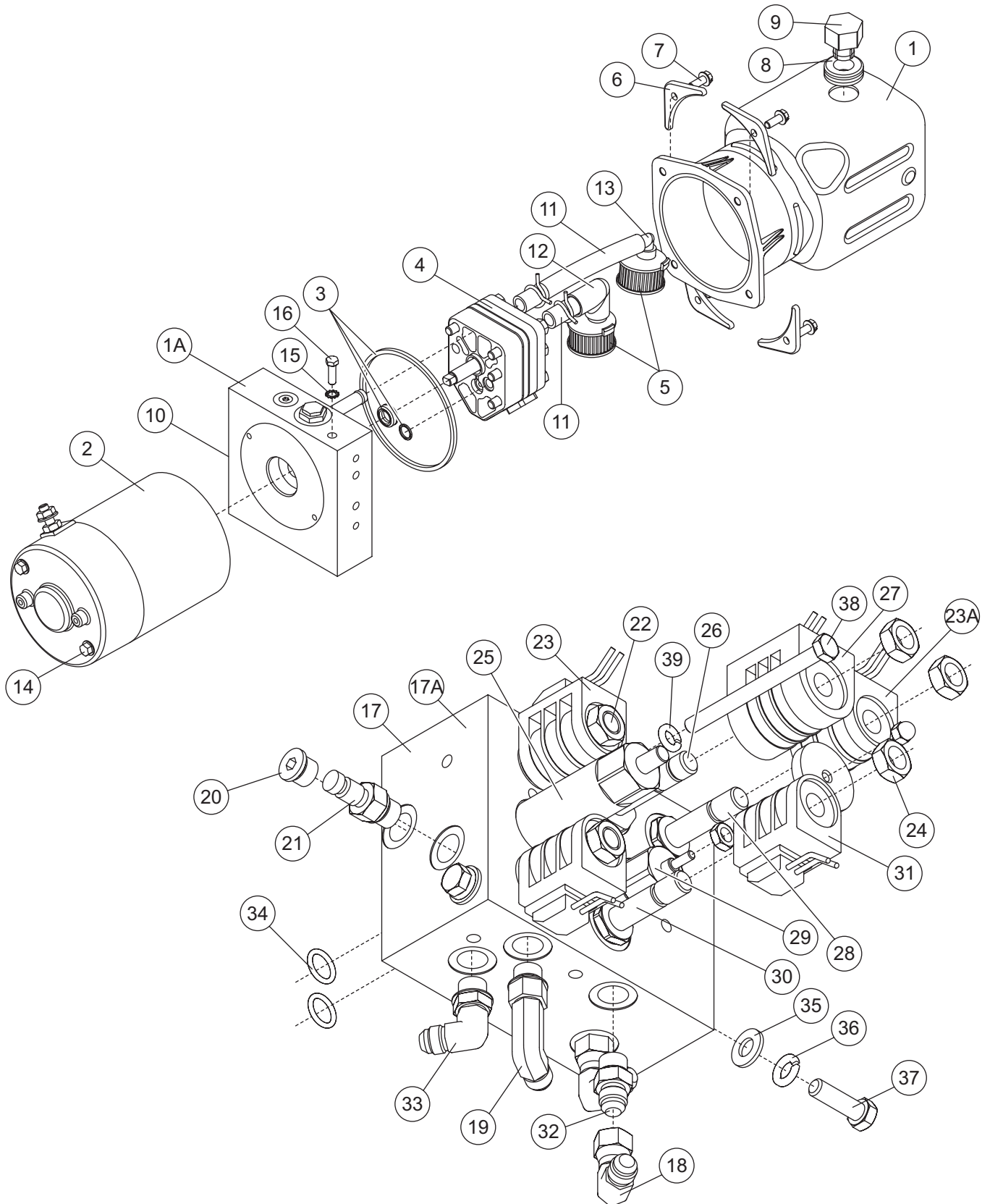

POWER UNIT PARTS – ALL MODELS

Item	Part	Qty	Description
1A	B60402	1	Hydraulic Pump Assembly Includes Item 1–2 & 4–14 (MTE)
1	B60433	1	Reservoir
2	B60434	1	Motor, 12VDC
3	B60435	1	Seal Kit
4	B60436	1	Pump Assembly, 2.47CC/REV
5	B60437	2	Filter
6	B60438	4	Clamp, Reservoir
7	B60439	4	Reservoir, Screw
8	B60345	1	Grommet
9	B60346	1	Breather
10	B60440	1	Relief Valve Asm.
11	B60450	2	Tube, Cut to Length
12	B60442	1	Elbow
13	B60444	1	Elbow
14	B61716	2	Screw, 1/4-20 x 6-3/16 Coarse Thread HHCS Gr 5 Zinc
15	B61307	1	3/8" Lock Washer, Internal/External Tooth, Zinc Plated
16	B61012	1	3/8-16 NC x 3/4" Gr 8 Bolt, Pump Cover and Mount
–	B60445	1	Brush Kit - for B60434 Motor
17A	B60270	1	Manifold Assembly Includes Item 17–23A, 24–26, 28–30, 32 & 33
17	B60269	1	Manifold Block (with Cross Port Relief), Red Anodized Aluminum
18	B60006	2	Hydraulic Adapter, 9/16"-18 90° Swivel Elbow
19	B60072	1	Hydraulic Adapter, 9/16"-18 x 9/16"-18 Male Extra Long Elbow
20	B60050	2	Plug, -6 SAE Hollow Hex
21	B60173	1	Coupling, Test Port, 7/16"-20 O.R.B.
22	B60167	2	Valve, Spool, Four-Way, Two Position C.C.
23A	B62148	1	Coil Harness Assy Incl. Item 23, 27 & 31, B62045, B62096, B62097, B62116 & B62117
–	B62045	1	Connector, Electric, Male, Plastic
–	B62096	15	Seal, Cable, Silicone, Orange (18 AWG)
–	B62097	5	Terminal, Male (18-16 AWG)
–	B62116	5	Silicone Cavity Plug, White (18-16 AWG)
–	B62117	1	Terminal, End Ring, 3/8" I.D. Copper, 8 Gauge
23	B62114	3	Coil, PDL 10V DC
24	B60052	5	Nut, 1/2"-20 Hex Jam YZ
25	B60168	1	Valve, Relief, 3000 PSI
26	B60170	1	Valve, Spool, Three-Way, Two Position
27	B62115	1	Coil, DDL 10V DC
28	B60166	1	Valve, Spool, Three-Way, Two Position
29	B61069	1	Valve, Flow Control
30	B60165	1	Valve, N.C., Two-Way
31	B62176	1	Coil, PDL 12V DC, Delta (waterproof, w/ O-rings)
32	B60007	2	Hydraulic Adapter, 9/16"-18 x 9/16"-18 Male O.R.B. Connector
33	B60005	1	Hydraulic Adapter, 9/16"-18 x 9/16"-18 90° Adjustable Elbow O.R.B.
34	B60038	2	O-ring, 3/32" C.S.W. 9/16" I.D., 3/4" O.D. Neoprene, 70 Durometer
35	B61016	2	Washer, 3/8" SAE Hardened
36	B61222	2	Washer, 3/8" Split Lock YZ
37	B61214	2	Screw, 3/8"-16 x 1-1/4" HHCS Gr8 YZ
38	B61010	2	Screw, 5/16"-18 x 3-3/4" HHCS Gr8 YZ
39	B61011	2	Washer, 5/16" Split Lock YZ

LIGHTS, DRAW LATCH & CONTROL PARTS – ALL MODELS

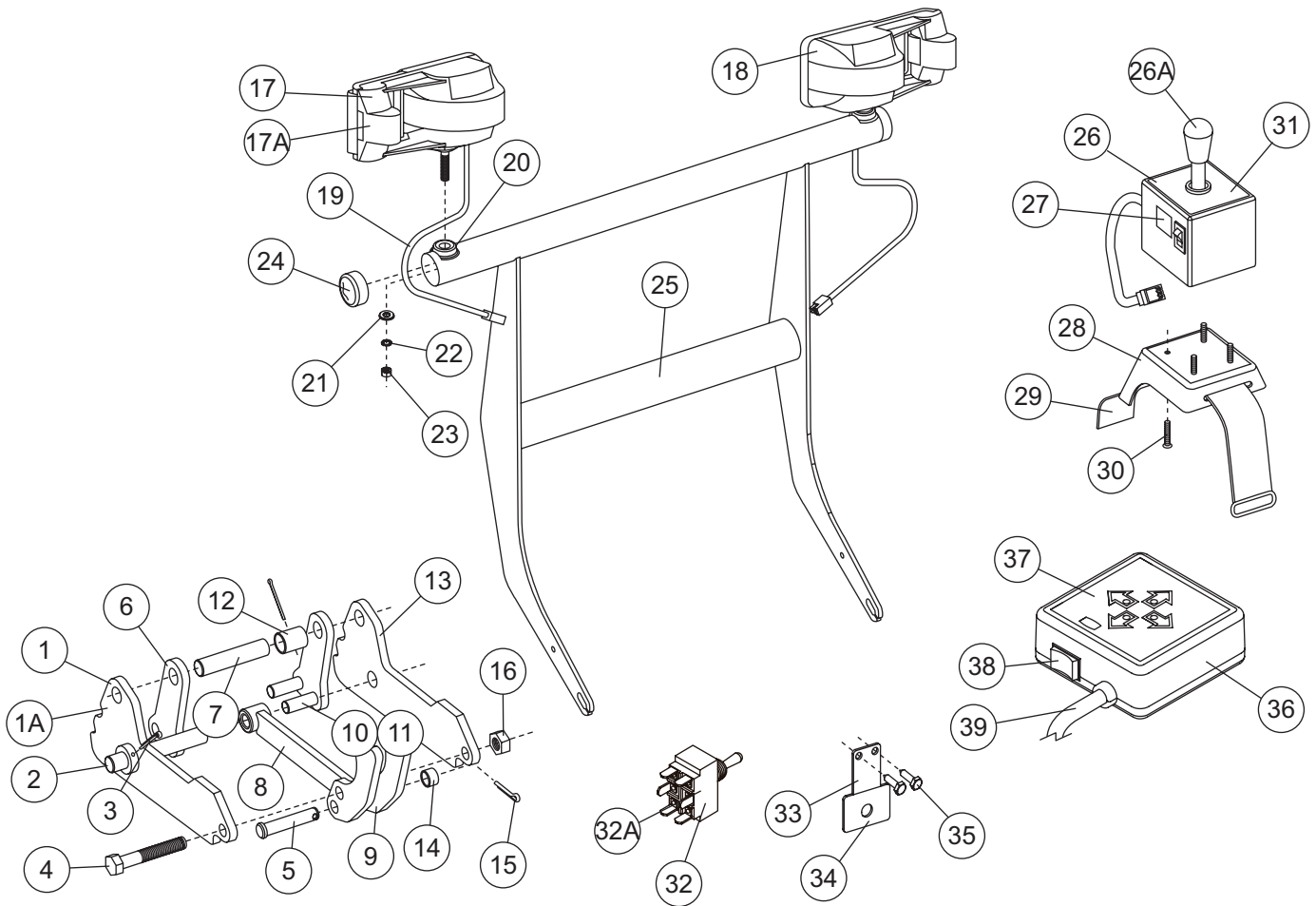

Item	Part	Qty		Description
		760LT	HD	
1A	B82049	1	–	Draw Latch Assembly Includes Item 1–16
	B40109	–	1	
1	B82035	1	–	Outer Draw Latch Plate Weldment, Driver's Side
	B40080	–	1	
2	B82050	1	–	Pin, Draw, 1" Dia. x 5-5/8" (with 13/64" Dia. Cotter Pin Hole) BZ
	B40110	–	1	
3	B61363	2	2	Pin, Cotter, 3/16" Dia. x 2-1/2" Z
4	B61200	1	–	Screw, 3/4"-10 x 4" HHCS Gr8 YZ
	B61004	–	1	
5	B82055	1	–	Pin, 3/4" Dia. x 3-7/16" Clevis YZ
	B50071	–	1	
6	B82014	2	–	Inner Draw Latch Plate
	B40074	–	2	
7	B82027	1	–	Pin, 1" x 3-7/8" Draw Latch Mount (To A-frame) YZ
	B40070	–	1	
8	B82054	1	–	Draw Latch Arm Weldment
	B40114	–	1	

LIGHTS, DRAW LATCH & CONTROL PARTS – ALL MODELS

Item	Part	Qty		Description
		760LT	HD	
9	B82058	1	–	Draw Latch Finger Weldment
	B40123	–	1	
10	B82033	1	–	Pin, 5/8" x 2-3/8" Inner Draw Latch Plate/Hydraulic Cylinder Rod End
	B40042	–	2	Pin, 3/4" x 2-1/2", Draw Latch Arm Pivot Pin/Hydraulic Cylinder Rod End
11	B82024	1	–	Pin, 3/4" x 2-3/8", Draw Latch Arm Pivot
12	B40093	1	1	Bushing, 1-1/4" O.D. x 1-1/16" I.D. x 1-1/2" YZ
13	B82036	1	–	Outer Draw Latch Plate Weldment, Passenger's Side
	B40081	–	1	
14	B40116	1	1	Spacer, 1" O.D. x 25/32" I.D. x 5/8" YZ
15	B61357	1	1	Pin, Cotter, 1/4" x 1-1/2" Z
16	B61006	1	1	Nut, 3/4"-10 Top Lock Z
17A	B61106	1	1	Headlight Assembly, Plow Includes Item 17–23 & B62061
17	B61107	1	1	Headlight, Driver's Side
18	B61108	1	1	Headlight, Passenger's Side
19	B62032	2	2	Harness (with 6-pin plug), Plow Headlight Side
20	B61231	1	1	Adapter, Headlight Ball Stud Mount
21	B61550	2	2	Washer, 1/2" I.D. x 1" O.D. Neoprene Backing Galvanized
22	B61112	2	2	Washer, 7/16" Ext. Tooth Lock YZ
23	B61111	2	2	Nut, 7/16"-14 Hex Gr8 YZ
–	B62108	2	2	Lighting Harness Repair Kit, Harness Side
–	B62061	2	2	Bulb, Sealed Beam Halogen (H6545/H4666)
–	B62062	1	1	Corrosion Preventive Compound (2fl.oz.)
24	B61427	2	2	Cap, 2-1/4" I.D., 2-3/8" O.D. x 3/4", Black Vinyl
25	B39034	1	–	Light Tower
	B39032	–	1	
26A	B62073	1	1	Control Station Assembly, Joystick Includes Item 26, 27 & 31
26	B62074	1	1	Control Station, Joystick
27	B63106	1	1	Label, Plow Power Switch, On/Off (Blz1061)
28	B61185	1	1	Base Plate, Joystick Control Station 1/8" ABS Plastic
29	B61127	1	1	Strap, (Hook and Loop Fastener with 2" D-Ring) 61" Black
30	B61254	4	4	Screw, 8-32 x 3/4" Pan Head Machine Z
31	B61174	1	1	Label, Control Station, Joystick (Blz1017)
–	B62185	1	1	Switch-Rocker SPDT On-Off-On - Straight Blade Joystick Control Switch
–	B62186	1	1	Switch-Straight Blade Joystick Functions
–	B62187	1	1	Relay-Straight Blade Joystick
–	B62188	1	1	Switch Actuator
–	B62189	1	1	Kit-Handle Straight Blade Joystick (Includes Shaft, Sleeve, E-Ring).
–	B62190	1	1	Mounting Plate
32A	B62138	1	1	Plow/Vehicle Headlight Toggle Switch Connection Kit (Includes Item 32–35)
32	B62024	1	1	On-On Toggle Switch, DPDT, 20A/125VAC
33	B61041	1	1	Bracket, Plow/Vehicle Headlight Toggle Switch
34	B61088	1	1	Label, Plow/Vehicle Headlight Toggle Switch Bracket (Blz1008)
35	B61031	5	5	Screw, 12-14 x 3/4" Hex Washer Self-Drilling
–	B62126	1	1	24" Ground Lead (Green/Yellow) with #10 Ring Terminal
–	B62127	1	1	24" On/Off Plow Light Switch Lead (Green/Yellow) with Two 1/4" Receptacles
36	B62142	1	1	Touchpad Control Station (Includes Item 37–39)
37	B62192	1	1	Kit, Decal Touchpad w/Adhesive Pads
38	B62191	1	1	PCB, Touchpad Control
39	B62202	1	1	Harness, Touchpad Control

HARNESSES, ACCESSORIES & KITS – ALL MODELS

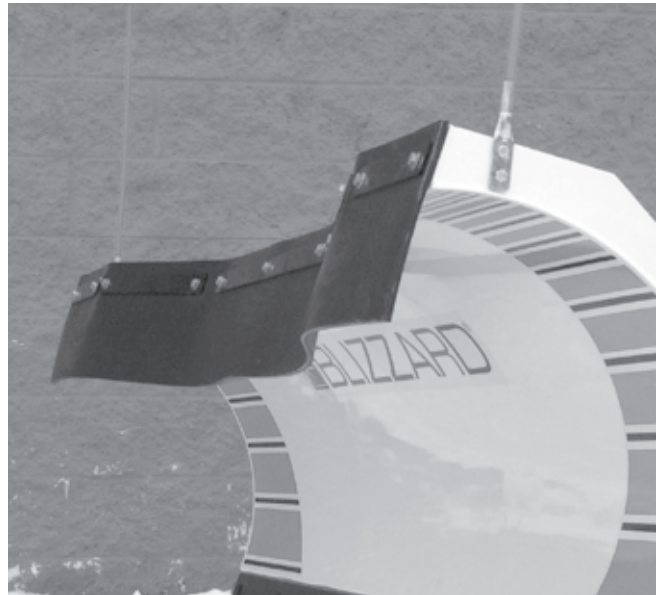
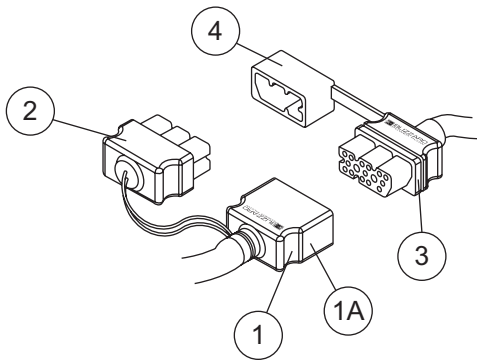

6. Rugged and durable, the 3/8" thick, 2-ply construction keeps snow off of your windshield and in its place—on the ground! The one piece rubber design allows for wing clearance and provides optimum snow deflection. The deflector is shipped complete mounting hardware.



5. Help channel air flow to your truck radiator during the long haul over the road. Mounted front and center, our custom airfoil redirects air over the top of the blade and into the grille of your vehicle. The airfoil is shipped with complete mounting hardware.



7. This kit includes the most common replacement parts: Angle cylinder hose, lift cylinder hose, hitch pin w/hair pin cotter, angle cylinder clevis pin w/ cotter, 90° angle cylinder fitting, solenoid, POWER HITCH™ toggle switch, corrosion preventive compound (2 oz.) and 10A fuse. The compact & durable plastic case (13.5"x9"x3.3") allows for easy storage behind or under your seat.

HARNESSES, ACCESSORIES & KITS – ALL MODELS



8. BLIZZARD® hydraulic oil is specially formulated for use in BLIZZARD snowplows and can significantly enhance the operation and performance of the hydraulic system. BLIZZARD zinc-free hydraulic oil maintains its viscosity to temperatures as low as -60°F. BLIZZARD oil is available by the quart, gallon, case or 55-gallon drum.

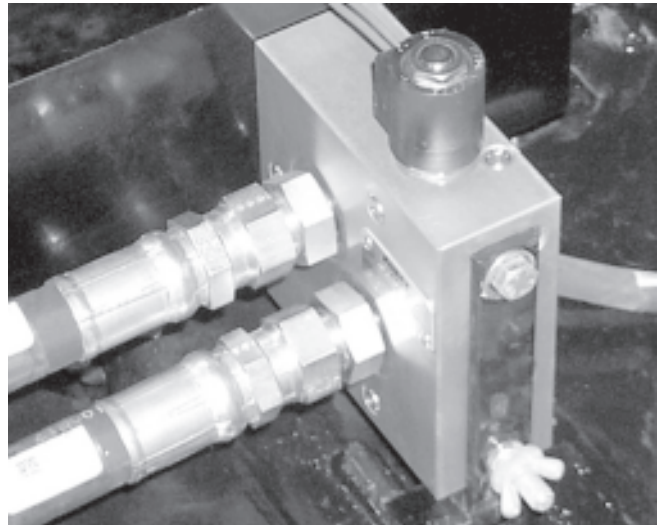

10. Get the response you demand from your plow with this easy-to install add-on and experience increased power and speed to all of the plow hydraulic functions! The auxiliary manifold bolts right up to the existing manifold and pump bracket without any modifications needed. Manifold provides up to 30 gpm input (4000 psi max.) from the vehicle pump and 2-3 gpm output (2500 psi max.) to the existing hydraulic manifold. Hydraulic hoses, fittings and pump not included.

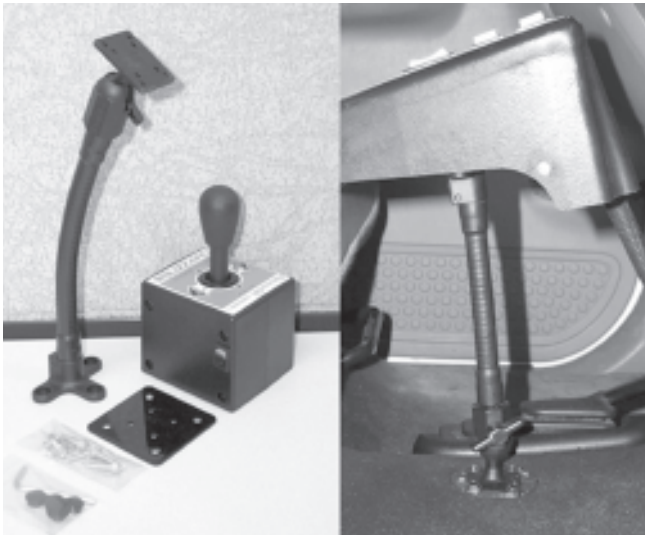

9. Our easy-to-install, adjustable pedestal mount will position either straight blade control station how you want it! Ideal for bucket seat vehicles with low center consoles. Pedestal accessory shipped with complete hardware and adapter plate.

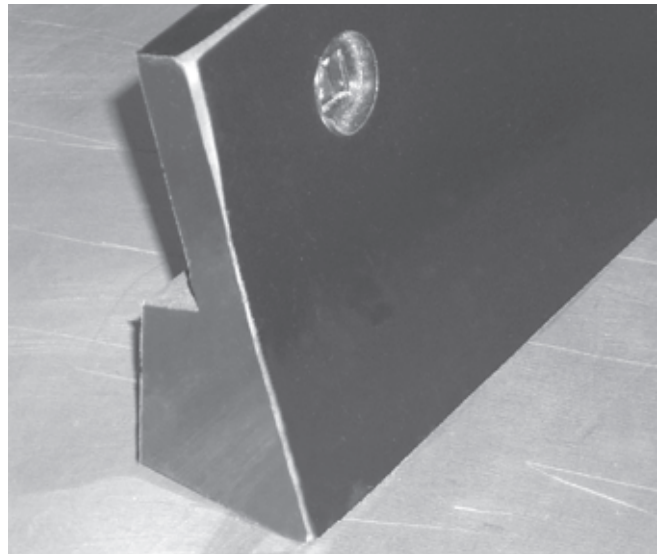

11. Durable and long lasting, polyurethane moldboard cutting edges will keep you plowing longer and safer! Specially formulated for snow plowing applications, BLIZZARD® poly edges resist gouging, provide superior wear life and effectively reduce plowing noise. Ideal for all plowing conditions. Edges are shipped with mounting hardware.

HARNESSES, ACCESSORIES & KITS – ALL MODELS



12. This adjustable bracket mounts easily to your straight blade joystick control and installs quickly onto any door panel. Ideal for left-hand joystick operation or for vehicles with center consoles. The window mount bracket is shipped complete with hardware. Some assembly required.



13. Putting your snowplow away for the winter? Have a deep scratch to cover? Clean up your blade and plow parts with our gloss spray paints. BLIZZARD touch-up paint provides an excellent finish to help keep your snowplow looking its best. Paint provided in 12 oz. spray cans.

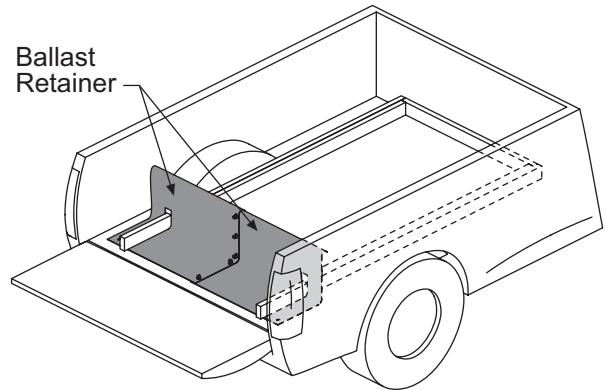

14. Ballast (additional weight) is an important part of qualifying vehicles for snowplow eligibility. Rear ballast must be used when necessary to remain in compliance with axle ratings and ratios as specified by the vehicle manufacturer. If ballast is required, it is important that it be secured properly behind the rear axle. A ballast retainer kit is available.

NOTE: The ballast retainer kit is for snowplow vehicles requiring ballast. See your sales outlet for the correct amount of ballast required. Include the weight of the retainer as part of the ballast requirement. Sand bags are recommended for use as ballast.

HARNESSES, ACCESSORIES & KITS – ALL MODELS

Item	Part	Qty				Description
		760LT	760HD	800HD	860HD	
1A	B62039	1	1	1	1	Harness Assembly, Plow Incl. Item 1,2 & B62046, B62093, B61439, B62167
1	B62057	1	1	1	1	Harness, Plow
2	B62001	1	1	1	1	Weather Cap, Rubber, Plow Side
–	B62046	1	1	1	1	Connector, Electric, Female, Plastic
–	B62093	10	10	10	10	Terminal, Female (18-16AWG)
–	B61439	2	2	2	2	Cable Tie, Black, 15" Nominal Length Heavy Duty-120psi Min Tensile - .3" Wide
–	B62167	1	1	1	1	Harness, Diode Loop
3	B62150	1	1	1	1	Harness, Vehicle
4	B62000	1	1	1	1	Weather Cap, Rubber, Vehicle Side
–	B62124	1	1	1	1	Fuse, 1/4" Dia. x 1-1/4" BUSS ARC 15A, 32V
–	B62212	1	1	1	1	Harness, Main Lighting
–	B62035	2	2	2	2	Weather Cap, Rubber, Lighting Harness
–	B62144	4	4	4	4	Headlight Relay, CB1-D-12V,
–	B62042	1	–	–	–	Power Contactor (Solenoid), 12 v Continuous
–	B62178	–	1	1	1	Power Contactor (Solenoid), 12VDC-225A
–	B62056	1	1	1	1	Ground Wire, Power Contactor, 24"
–	B62072	4	4	4	4	Terminal, End Ring, 3/8" I.D. Copper, 4 Gauge
–	B62008	1	1	1	1	Fuse Clip, Mini
–	B62009	1	1	1	1	Fuse Clip, Auto Blade
–	B62016	4	4	4	4	Connector, Splice Lock (18-14 WAG)
–	B61031	3	3	3	3	Screw, 12-14 x 3/4"Hex Washer Self-Drilling
5	B81041	1	–	–	–	Snowplow Airfoil
	B52093	–	1	1	1	
6	B61243	1	–	–	–	Rubber Snow Deflector w/ hardware
	B61242	–	1	–	–	
	B61260	–	–	1	–	
	B61545	–	–	–	1	
7	B63074	1	1	1	1	Emergency Parts Kit
8	B63070	1	1	1	1	BLIZZARD® Rapid Action Hydraulic Oil-Quart
	B63071	1	1	1	1	Case (12 quarts)
	B63072	1	1	1	1	Gallon
	B63069	1	1	1	1	Case (4 gallons)
	B63091	1	1	1	1	Drum (55 gallons)
9	B63078	1	1	1	1	12" Adjustable Pedestal Mount
10	B60310	1	1	1	1	Central Hydraulic Valve Block
11	B61544	1	1	–	–	Polyurethane Moldboard Cutting Edges (with Hardware)
	B61543	–	–	1	–	
	B61542	–	–	–	1	
12	B61261	1	1	1	1	Straight Blade Joystick Window Mount Bracket
13	B61219	1	1	1	1	BLIZZARD High Performance 12 Oz. Spray Paint, Gloss White
	B63073	1	1	1	1	BLIZZARD High Performance 12 Oz. Spray Paint, Gloss Black
14	62849	1	1	1	1	Ballast Retainer Kit

HARNESSES, ACCESSORIES & KITS – ALL MODELS

Kits						
Item	Part	Qty				Description
		760LT	760HD	800HD	860HD	
-	B61354	1	-	-	-	Kit, Hardware, Snowplow Assembly Parts
-	B61353	-	1	1	1	
-	B60276	1	1	1	1	Kit, Hydraulic Adapter Incl. B60005 (3), B60006 (2), B60007 (3), B60072 (1) & B60272 (1)
-	B60281	1	1	1	1	Kit, Hydraulic Hose Incl. B60091(2), B60273(1) & B60274(1)
-	B61255	1	1	1	1	Kit, Hardware, Moldboard Cutting Edge
-	B61256	1	-	-	-	Kit, Cutting Edge, Moldboard w/Hardware
-	B61258	-	1	-	-	
-	B61259	-	-	1	-	
-	B61532	-	-	-	1	
-	B60360	1	1	1	1	
-	B60368	1	-	-	-	Combo Seal Kit, Cyl B60029/B60065
-	B60371	-	1	1	1	Combo Seal Kit, Cyl B60236
-	B62195	1	1	1	1	Combo Seal Kit, Cyl B60255
-	B62195	1	1	1	1	Kit, Headlamp B61106 (1-sealed beam, 1-rim , 4-spacer bumpers, 4-screws)
-	B62196	1	1	1	1	Kit, Headlamp B61106 Signal (1-bulb, 1-turn signal lens, 1- gasket, 2-screws)

NOTES



Blizzard Snowplows
23199 Airpark Blvd.
Calumet, MI 49913
www.blizzardplows.com



 A DIVISION OF DOUGLAS DYNAMICS, L.L.C.

Copyright © 2006 Douglas Dynamics, L.L.C. All rights reserved. This material may not be reproduced or copied, in whole or in part, in any printed, mechanical, electronic, film or other distribution and storage media, without the written consent of Blizzard. Authorization to photocopy items for internal or personal use by BLIZZARD® outlets or snowplow owner is granted.

Blizzard reserves the right under its product improvement policy to change construction or design details and furnish equipment when so altered without reference to illustrations or specifications used. Blizzard or the vehicle manufacturer may require or recommend optional equipment for snow removal. Do not exceed vehicle ratings with a snowplow. This product is manufactured under the following U.S. Patents: 5,638,618; 5,899,007; 6,178,669; 6,276,076; 6,393,737; 6,408,549; 6,412,199; 6,442,877; 6,615,513; Canadian and other patents pending. Blizzard offers a limited warranty for all snowplows and accessories. See separately printed page for this important information. The following are registered (®) or unregistered (™) trademarks of Douglas Dynamics, L.L.C.: BLIZZARD®, POWER HITCH™.

Printed in U.S.A.